

How it Works: Convolutional Neural Networks

Slide: http://brohrer.github.io/how_convolutional_neural_networks_work.html

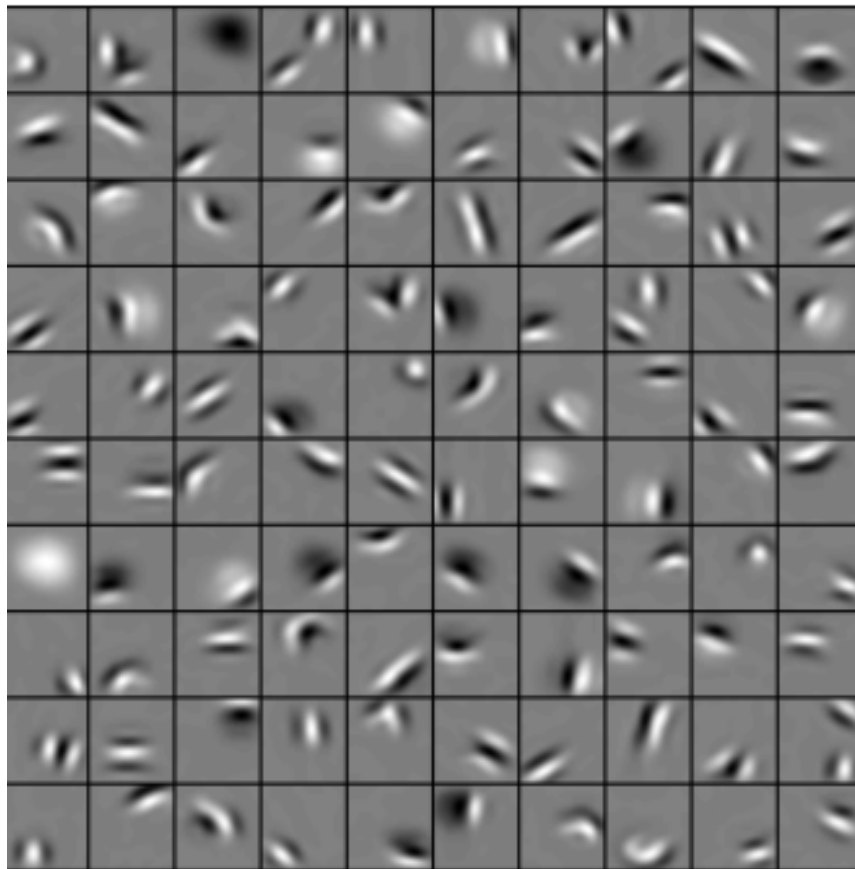

faces



cars



Convolutional Deep Belief Networks for Scalable Unsupervised Learning of Hierarchical Representations
Honglak Lee, Roger Grosse, Rajesh Ranganath, Andrew Y. Ng

A toy ConvNet: X's and O's

Says whether a picture is of an X or an O

A two-dimensional
array of pixels

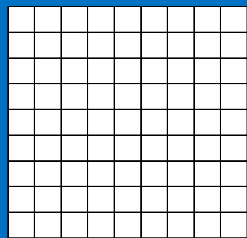

X or **O**

For example

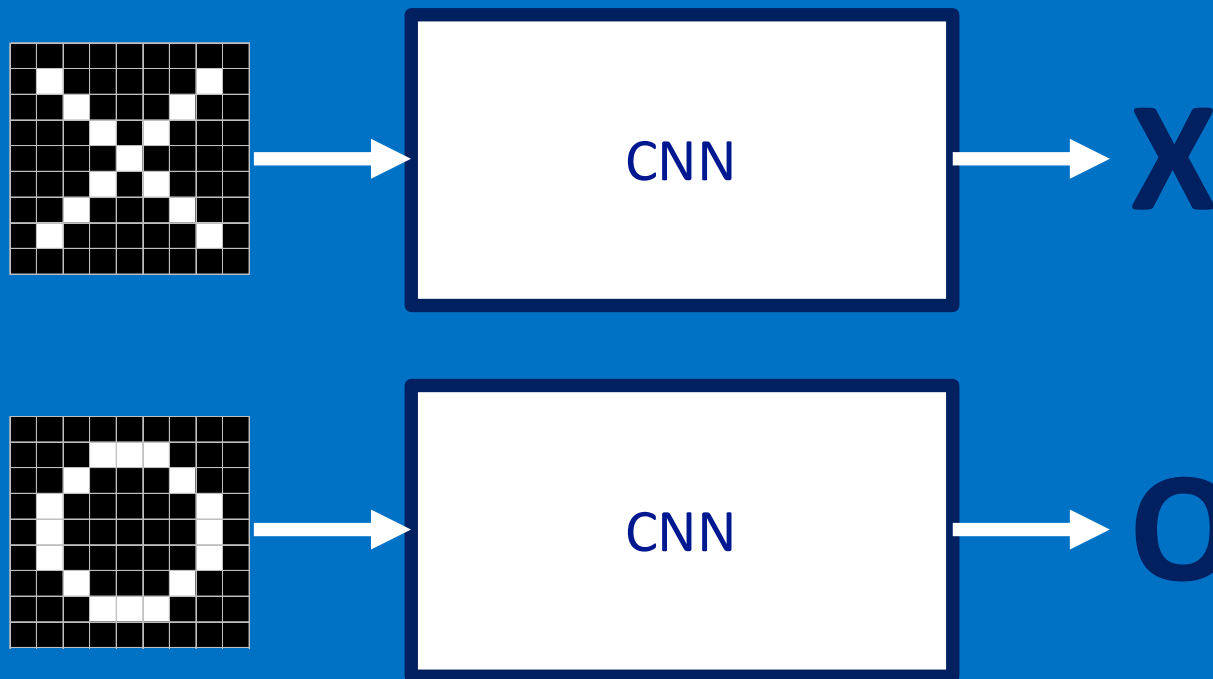

Trickier cases

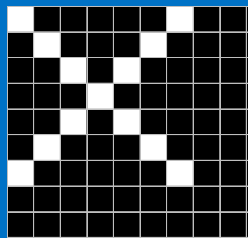

translation

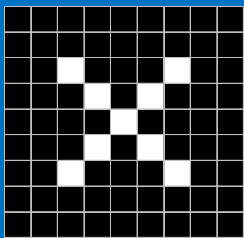

scaling

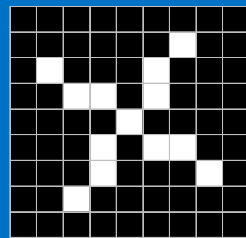

rotation

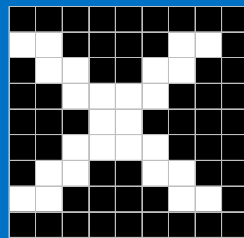

weight

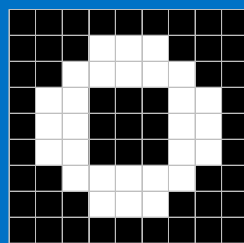
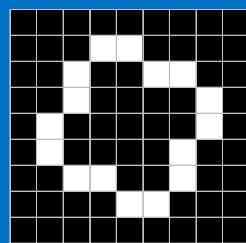
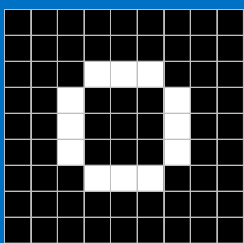
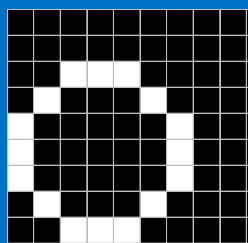

Deciding is hard

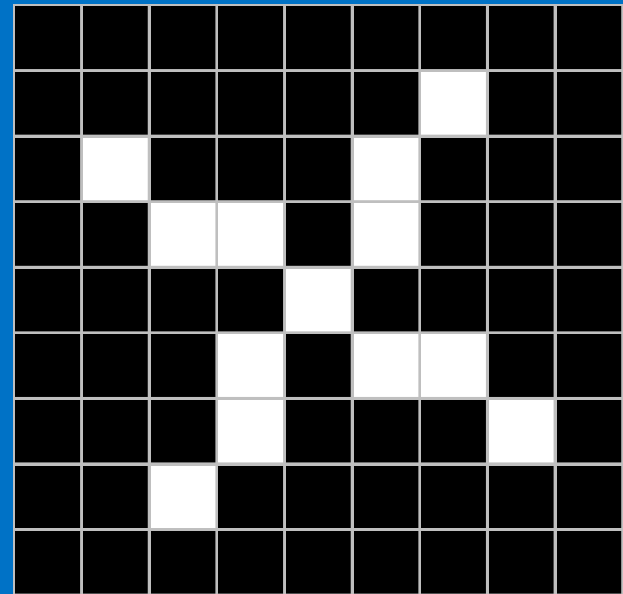
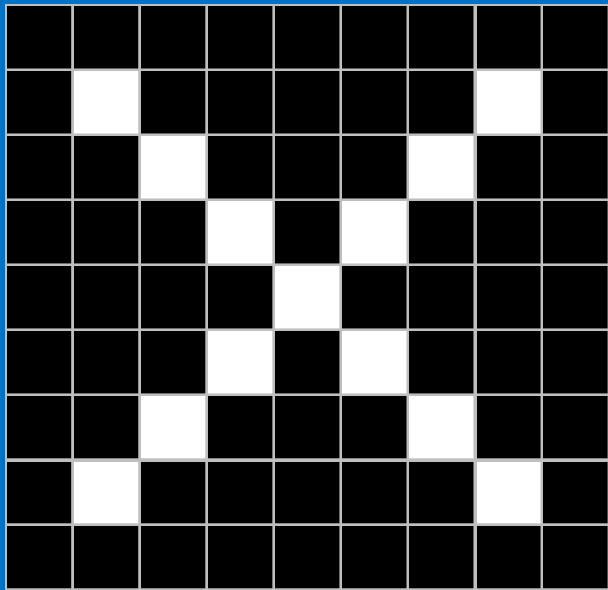

ConvNets match pieces of the image

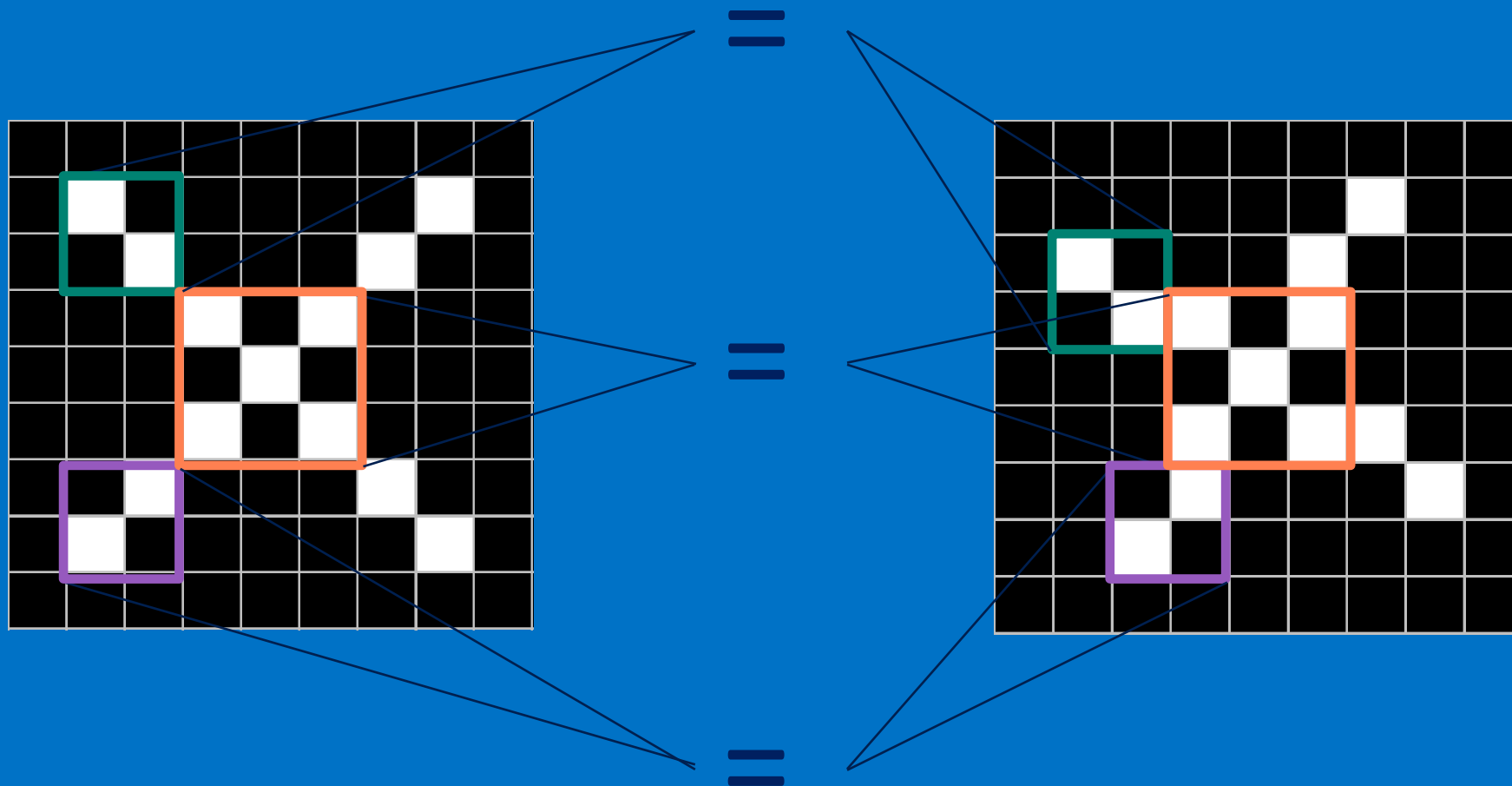

Features match pieces of the image

1	-1	-1
-1	1	-1
-1	-1	1

1	-1	1
-1	1	-1
1	-1	1

-1	-1	1
-1	1	-1
1	-1	-1

1	-1	-1
-1	1	-1
-1	-1	1

1	-1	1
-1	1	-1
1	-1	1

-1	-1	1
-1	1	-1
1	-1	-1

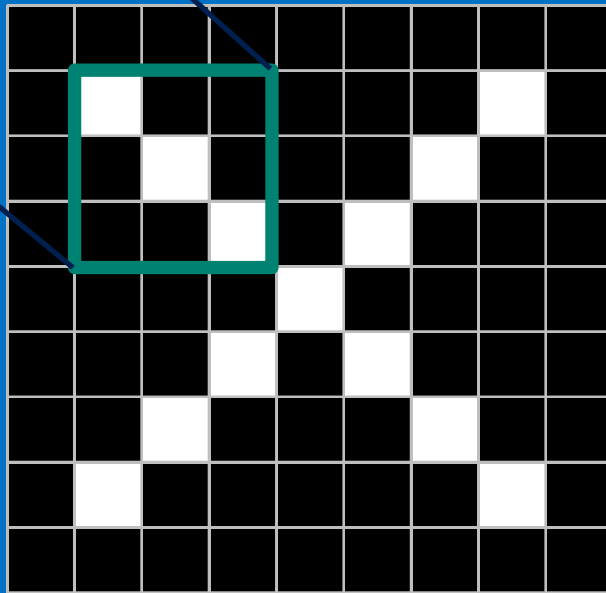

1	-1	-1
-1	1	-1
-1	-1	1

1	-1	1
-1	1	-1
1	-1	1

-1	-1	1
-1	1	-1
1	-1	-1

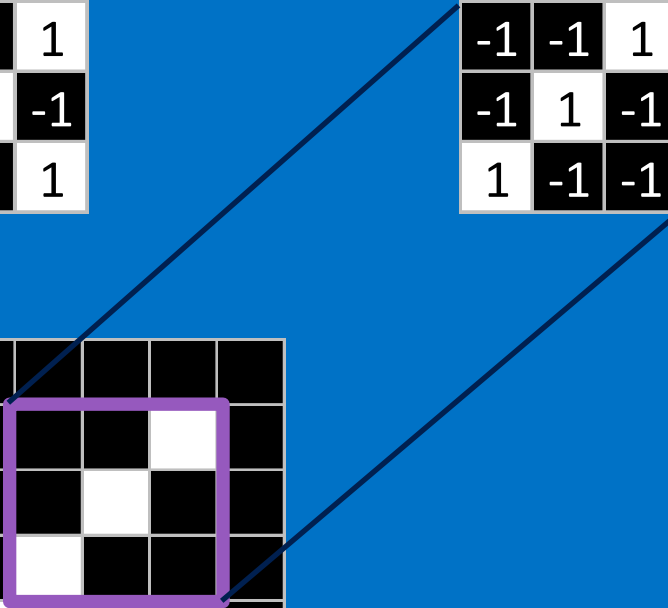
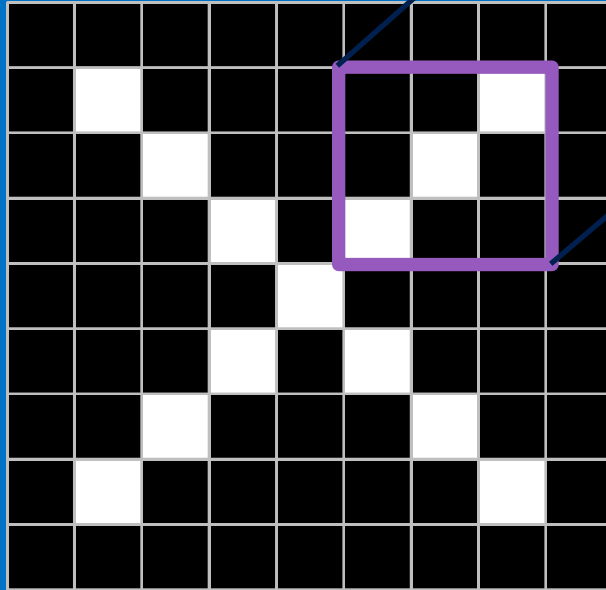

1	-1	-1
-1	1	-1
-1	-1	1

1	-1	1
-1	1	-1
1	-1	1

-1	-1	1
-1	1	-1
1	-1	-1

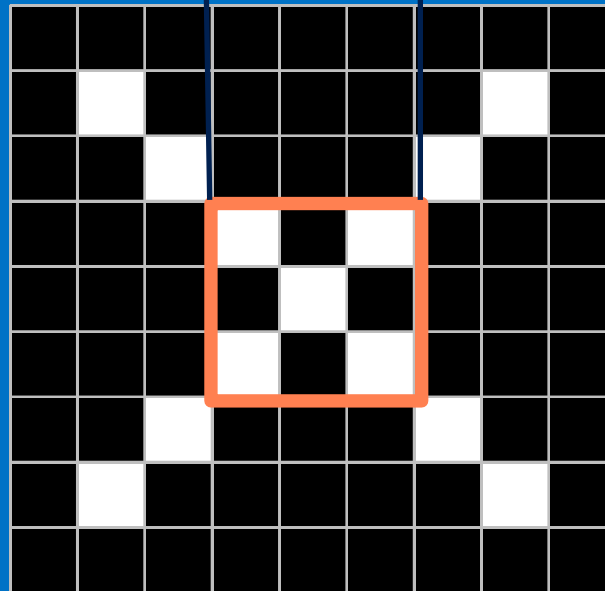

1	-1	-1
-1	1	-1
-1	-1	1

1	-1	1
-1	1	-1
1	-1	1

-1	-1	1
-1	1	-1
1	-1	-1

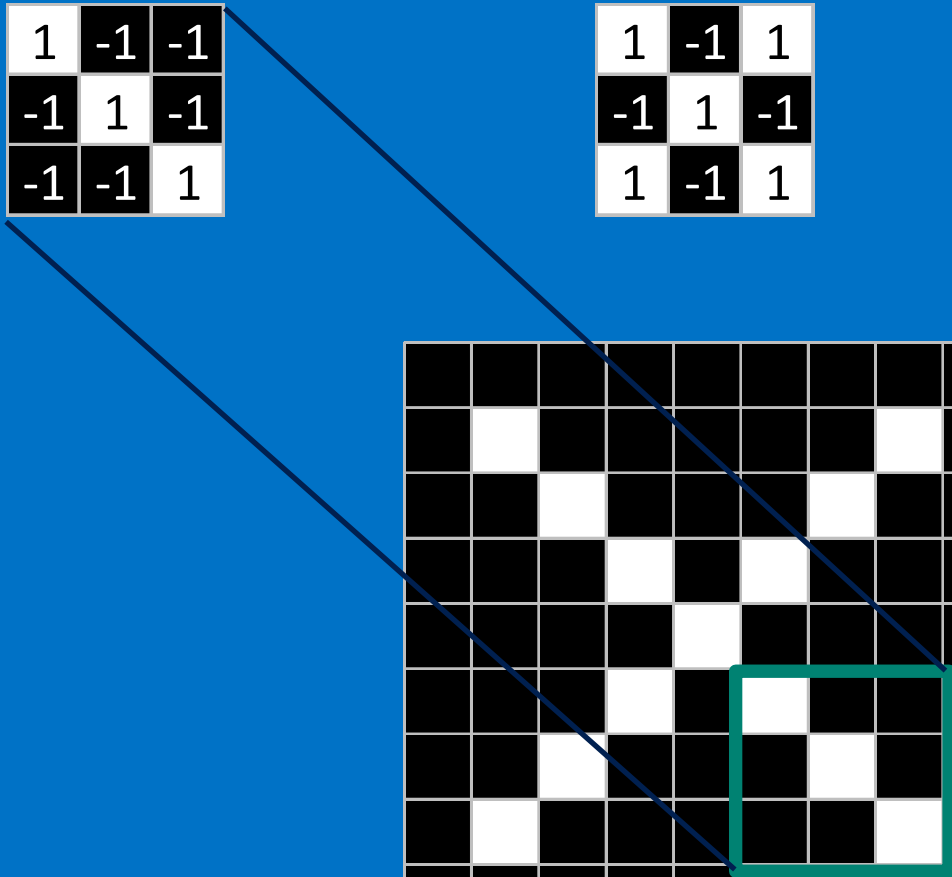
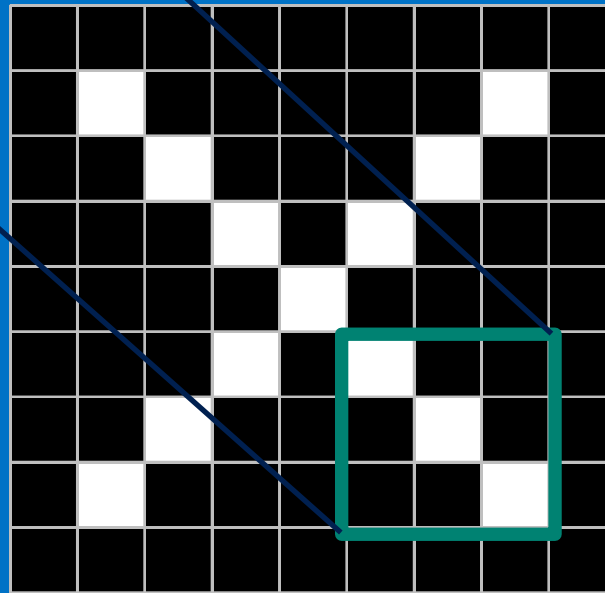

1	-1	-1
-1	1	-1
-1	-1	1

1	-1	1
-1	1	-1
1	-1	1

-1	-1	1
-1	1	-1
1	-1	-1

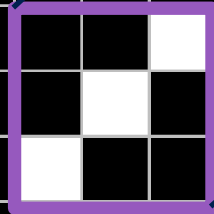
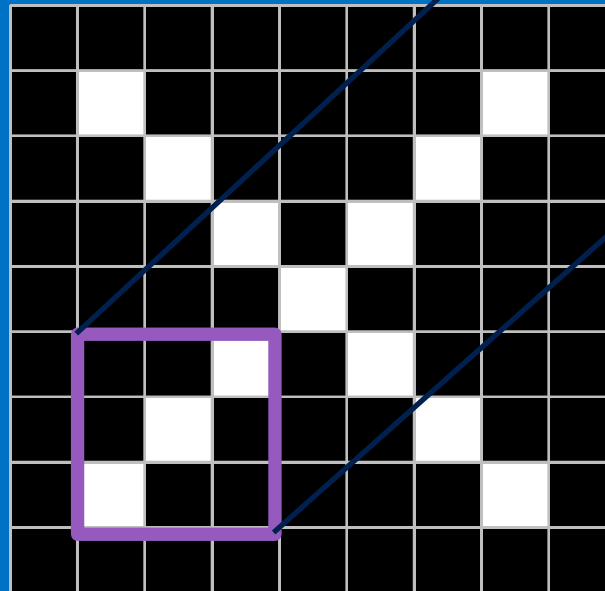

Filtering: The math behind the match

1. Line up the feature and the image patch.
2. Multiply each image pixel by the corresponding feature pixel.
3. Add them up.
4. Divide by the total number of pixels in the feature.

Filtering: The math behind the match

1	-1	-1
-1	1	-1
-1	-1	1

$$1 \times 1 = 1$$

-1	-1	-1	-1	-1	-1	-1	-1	-1
-1	1	-1	-1	-1	-1	-1	1	-1
-1	-1	1	-1	-1	-1	1	-1	-1
-1	-1	-1	1	-1	1	-1	-1	-1
-1	-1	-1	-1	1	-1	-1	-1	-1
-1	-1	-1	1	-1	1	-1	-1	-1
-1	-1	1	-1	-1	-1	1	-1	-1
-1	1	-1	-1	-1	-1	-1	1	-1
-1	-1	-1	-1	-1	-1	-1	-1	-1

1		

Filtering: The math behind the match

1	-1	-1
-1	1	-1
-1	-1	1

$$-1 \times -1 = 1$$

-1	-1	-1	-1	-1	-1	-1	-1	-1
-1	1	-1	-1	-1	-1	-1	1	-1
-1	-1	1	-1	-1	-1	1	-1	-1
-1	-1	-1	1	-1	1	-1	-1	-1
-1	-1	-1	-1	1	-1	-1	-1	-1
-1	-1	-1	1	-1	1	-1	-1	-1
-1	-1	1	-1	-1	-1	1	-1	-1
-1	1	-1	-1	-1	-1	-1	1	-1
-1	-1	-1	-1	-1	-1	-1	-1	-1

1	1	

Filtering: The math behind the match

1	-1	-1
-1	1	-1
-1	-1	1

$$-1 \times -1 = 1$$

-1	-1	-1	-1	-1	-1	-1	-1	-1
-1	1	-1	-1	-1	-1	-1	1	-1
-1	-1	1	-1	-1	-1	1	-1	-1
-1	-1	-1	1	-1	1	-1	-1	-1
-1	-1	-1	-1	1	-1	-1	-1	-1
-1	-1	-1	1	-1	1	-1	-1	-1
-1	-1	1	-1	-1	-1	1	-1	-1
-1	1	-1	-1	-1	-1	-1	1	-1
-1	-1	-1	-1	-1	-1	-1	-1	-1

1	1	1

Filtering: The math behind the match

1	-1	-1
-1	1	-1
-1	-1	1

$$-1 \times -1 = 1$$

-1	-1	-1	-1	-1	-1	-1	-1	-1
-1	1	-1	-1	-1	-1	-1	1	-1
-1	-1	1	-1	-1	-1	1	-1	-1
-1	-1	-1	1	-1	1	-1	-1	-1
-1	-1	-1	-1	1	-1	-1	-1	-1
-1	-1	-1	1	-1	1	-1	-1	-1
-1	-1	1	-1	-1	-1	1	-1	-1
-1	1	-1	-1	-1	-1	-1	1	-1
-1	-1	-1	-1	-1	-1	-1	-1	-1

1	1	1
1		

Filtering: The math behind the match

1	-1	-1
-1	1	-1
-1	-1	1

$$-1 \times -1 = 1$$

-1	-1	-1	-1	-1	-1	-1	-1	-1
-1	1	-1	-1	-1	-1	-1	1	-1
-1	-1	1	-1	-1	-1	1	-1	-1
-1	-1	-1	1	-1	1	-1	-1	-1
-1	-1	-1	-1	1	-1	-1	-1	-1
-1	-1	-1	1	-1	1	-1	-1	-1
-1	-1	1	-1	-1	-1	1	-1	-1
-1	1	-1	-1	-1	-1	-1	1	-1
-1	-1	-1	-1	-1	-1	-1	-1	-1

1	1	1
1	1	1
1		

Filtering: The math behind the match

1	-1	-1
-1	1	-1
-1	-1	1

$$-1 \times 1 = 1$$

-1	-1	-1	-1	-1	-1	-1	-1	-1
-1	1	-1	-1	-1	-1	-1	1	-1
-1	-1	1	-1	-1	-1	1	-1	-1
-1	-1	-1	1	-1	1	-1	-1	-1
-1	-1	-1	-1	1	-1	-1	-1	-1
-1	-1	-1	1	-1	1	-1	-1	-1
-1	-1	1	-1	-1	-1	1	-1	-1
-1	1	-1	-1	-1	-1	-1	1	-1
-1	-1	-1	-1	-1	-1	-1	-1	-1

1	1	1
1	1	1
1	1	

Filtering: The math behind the match

1	-1	-1
-1	1	-1
-1	-1	1

$$1 \times 1 = 1$$

-1	-1	-1	-1	-1	-1	-1	-1	-1
-1	1	-1	-1	-1	-1	-1	1	-1
-1	-1	1	-1	-1	-1	1	-1	-1
-1	-1	-1	1	-1	1	-1	-1	-1
-1	-1	-1	-1	1	-1	-1	-1	-1
-1	-1	-1	1	-1	1	-1	-1	-1
-1	-1	1	-1	-1	-1	1	-1	-1
-1	1	-1	-1	-1	-1	-1	1	-1
-1	-1	-1	-1	-1	-1	-1	-1	-1

1	1	1
1	1	1
1	1	1

Filtering: The math behind the match

1	-1	-1
-1	1	-1
-1	-1	1

$$1 \times 1 = 1$$

-1	-1	-1	-1	-1	-1	-1	-1	-1
-1	1	-1	-1	-1	-1	-1	1	-1
-1	-1	1	-1	-1	-1	1	-1	-1
-1	-1	-1	1	-1	1	-1	-1	-1
-1	-1	-1	-1	1	-1	-1	-1	-1
-1	-1	-1	1	-1	1	-1	-1	-1
-1	-1	1	-1	-1	-1	1	-1	-1
-1	1	-1	-1	-1	-1	-1	1	-1
-1	-1	-1	-1	-1	-1	-1	-1	-1

1		

Convolution: Trying every possible match

1	-1	-1
-1	1	-1
-1	-1	1

-1	-1	-1	-1	-1	-1	-1	-1	-1
-1	1	-1	-1	-1	-1	-1	1	-1
-1	-1	1	-1	-1	-1	1	-1	-1
-1	-1	-1	1	-1	1	-1	-1	-1
-1	-1	-1	-1	1	-1	-1	-1	-1
-1	-1	-1	1	-1	1	-1	-1	-1
-1	-1	1	-1	-1	-1	1	-1	-1
-1	1	-1	-1	-1	-1	-1	1	-1
-1	-1	-1	-1	-1	-1	-1	-1	-1



0.77	-0.11	0.11	0.33	0.55	-0.11	0.33
-0.11	1.00	-0.11	0.33	-0.11	0.11	-0.11
0.11	-0.11	1.00	-0.33	0.11	-0.11	0.55
0.33	0.33	-0.33	0.55	-0.33	0.33	0.33
0.55	-0.11	0.11	-0.33	1.00	-0.11	0.11
-0.11	0.11	-0.11	0.33	-0.11	1.00	-0.11
0.33	-0.11	0.55	0.33	0.11	-0.11	0.77

Convolution: Trying every possible match

-1	-1	-1	-1	-1	-1	-1	-1	-1
-1	1	-1	-1	-1	-1	-1	1	-1
-1	-1	1	-1	-1	-1	1	-1	-1
-1	-1	-1	1	-1	1	-1	-1	-1
-1	-1	-1	-1	1	-1	-1	-1	-1
-1	-1	-1	1	-1	1	-1	-1	-1
-1	-1	1	-1	-1	-1	1	-1	-1
-1	1	-1	-1	-1	-1	-1	1	-1
-1	-1	-1	-1	-1	-1	-1	-1	-1



1	-1	-1
-1	1	-1
-1	-1	1

=

0.77	-0.11	0.11	0.33	0.55	-0.11	0.33
-0.11	1.00	-0.11	0.33	-0.11	0.11	-0.11
0.11	-0.11	1.00	-0.33	0.11	-0.11	0.55
0.33	0.33	-0.33	0.55	-0.33	0.33	0.33
0.55	-0.11	0.11	-0.33	1.00	-0.11	0.11
-0.11	0.11	-0.11	0.33	-0.11	1.00	-0.11
0.33	-0.11	0.55	0.33	0.11	-0.11	0.77

-1	-1	-1	-1	-1	-1	-1	-1	-1
-1	1	-1	-1	-1	-1	-1	1	-1
-1	-1	1	-1	-1	-1	1	-1	-1
-1	-1	-1	1	-1	1	-1	-1	-1
-1	-1	-1	-1	1	-1	-1	-1	-1
-1	-1	-1	1	-1	1	-1	-1	-1
-1	-1	1	-1	-1	-1	1	-1	-1
-1	1	-1	-1	-1	-1	-1	1	-1
-1	-1	-1	-1	-1	-1	-1	-1	-1



1	-1	-1
-1	1	-1
-1	-1	1



0.77	-0.11	0.11	0.33	0.55	-0.11	0.33
-0.11	1.00	-0.11	0.33	-0.11	0.11	-0.11
0.11	-0.11	1.00	-0.33	0.11	-0.11	0.55
0.33	0.33	-0.33	0.55	-0.33	0.33	0.33
0.55	-0.11	0.11	-0.33	1.00	-0.11	0.11
-0.11	0.11	-0.11	0.33	-0.11	1.00	-0.11
0.33	-0.11	0.55	0.33	0.11	-0.11	0.77

-1	-1	-1	-1	-1	-1	-1	-1	-1
-1	1	-1	-1	-1	-1	-1	1	-1
-1	-1	1	-1	-1	-1	1	-1	-1
-1	-1	-1	1	-1	1	-1	-1	-1
-1	-1	-1	-1	1	-1	-1	-1	-1
-1	-1	-1	1	-1	1	-1	-1	-1
-1	-1	1	-1	-1	-1	1	-1	-1
-1	1	-1	-1	-1	-1	-1	1	-1
-1	-1	-1	-1	-1	-1	-1	-1	-1



1	-1	1
-1	1	-1
1	-1	1



0.33	-0.55	0.11	-0.11	0.11	-0.55	0.33
-0.55	0.55	-0.55	0.33	-0.55	0.55	-0.55
0.11	-0.55	0.55	-0.77	0.55	-0.55	0.11
-0.11	0.33	-0.77	1.00	-0.77	0.33	-0.11
0.11	-0.55	0.55	-0.77	0.55	-0.55	0.11
-0.55	0.55	-0.55	0.33	-0.55	0.55	-0.55
0.33	-0.55	0.11	-0.11	0.11	-0.55	0.33

-1	-1	-1	-1	-1	-1	-1	-1	-1
-1	1	-1	-1	-1	-1	-1	1	-1
-1	-1	1	-1	-1	-1	1	-1	-1
-1	-1	-1	1	-1	1	-1	-1	-1
-1	-1	-1	-1	1	-1	-1	-1	-1
-1	-1	-1	1	-1	1	-1	-1	-1
-1	-1	1	-1	-1	-1	1	-1	-1
-1	1	-1	-1	-1	-1	-1	1	-1
-1	-1	-1	-1	-1	-1	-1	-1	-1



-1	-1	1
-1	1	-1
1	-1	-1



0.33	-0.11	0.55	0.33	0.11	-0.11	0.77
-0.11	0.11	-0.11	0.33	-0.11	1.00	-0.11
0.55	-0.11	0.11	-0.33	1.00	-0.11	0.11
0.33	0.33	-0.33	0.55	-0.33	0.33	0.33
0.11	-0.11	1.00	-0.33	0.11	-0.11	0.55
-0.11	1.00	-0.11	0.33	-0.11	0.11	-0.11
0.77	-0.11	0.11	0.33	0.55	-0.11	0.33

Convolution layer

One image becomes a stack of filtered images

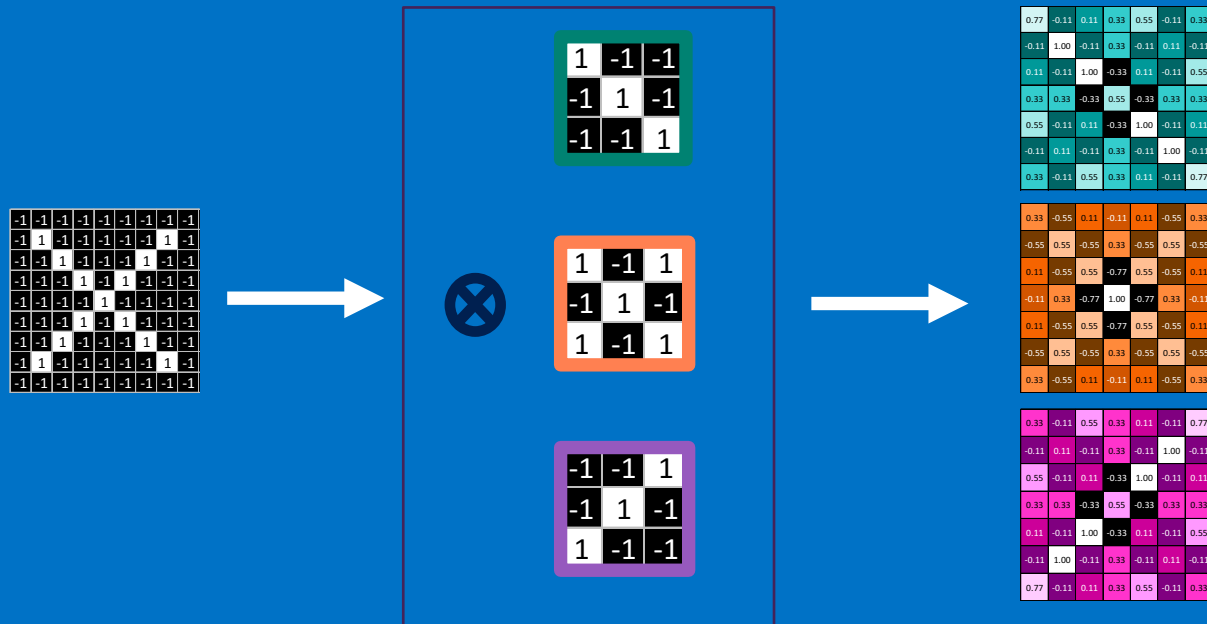

Convolution layer

One image becomes a stack of filtered images

-1	-1	-1	-1	-1	-1	-1	
-1	1	-1	-1	-1	-1	1	-1
-1	-1	1	-1	-1	1	-1	-1
-1	-1	-1	1	-1	1	-1	-1
-1	-1	-1	-1	1	-1	-1	-1
-1	-1	-1	-1	-1	1	-1	-1
-1	1	-1	-1	-1	1	-1	-1
-1	-1	-1	-1	-1	-1	1	-1
-1	-1	-1	-1	-1	-1	-1	1
-1	-1	-1	-1	-1	-1	-1	-1

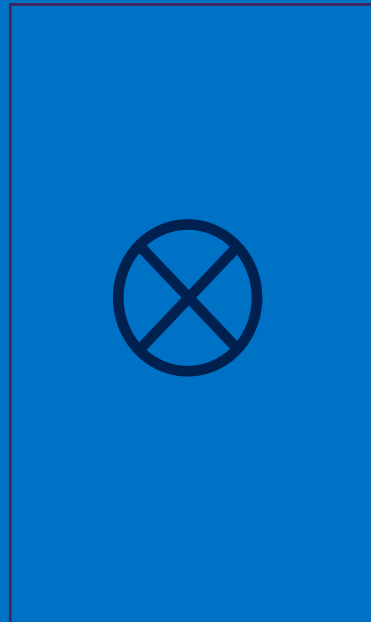

0.77	-0.11	0.11	0.33	0.55	-0.11	0.33
-0.11	1.00	-0.11	0.33	-0.11	0.11	-0.11
0.11	-0.11	1.00	-0.33	0.11	-0.11	0.55
0.33	0.33	-0.33	0.55	-0.33	0.33	0.33
0.55	-0.11	0.11	-0.33	1.00	-0.11	0.11
-0.11	0.11	-0.11	0.33	-0.11	1.00	-0.11
0.33	-0.11	0.55	0.33	0.11	-0.11	0.77

0.33	-0.55	0.11	-0.11	0.11	-0.55	0.33
-0.55	0.55	-0.55	0.33	-0.55	0.55	-0.55
0.11	-0.55	0.55	-0.77	0.55	-0.55	0.11
-0.11	0.33	-0.77	1.00	-0.77	0.33	-0.11
0.11	-0.55	0.55	-0.77	0.55	-0.55	0.11
-0.55	0.55	-0.55	0.33	-0.55	0.55	-0.55
0.33	-0.55	0.11	-0.11	0.11	-0.55	0.33

0.33	-0.11	0.55	0.33	0.11	-0.11	0.77
-0.11	0.11	-0.11	0.33	-0.11	1.00	-0.11
0.55	-0.11	0.11	-0.33	1.00	-0.11	0.11
0.33	0.33	-0.33	0.55	-0.33	0.33	0.33
0.11	-0.11	1.00	-0.33	0.11	-0.11	0.55
-0.11	1.00	-0.11	0.33	-0.11	0.11	-0.11
0.77	-0.11	0.11	0.33	0.55	-0.11	0.33

Pooling: Shrinking the image stack

1. Pick a window size (usually 2 or 3).
2. Pick a stride (usually 2).
3. Walk your window across your filtered images.
4. From each window, take the maximum value.

Pooling

maximum

0.77	-0.11	0.11	0.33	0.55	-0.11	0.33
-0.11	1.00	-0.11	0.33	-0.11	0.11	-0.11
0.11	-0.11	1.00	-0.33	0.11	-0.11	0.55
0.33	0.33	-0.33	0.55	-0.33	0.33	0.33
0.55	-0.11	0.11	-0.33	1.00	-0.11	0.11
-0.11	0.11	-0.11	0.33	-0.11	1.00	-0.11
0.33	-0.11	0.55	0.33	0.11	-0.11	0.77

1.00			

Pooling

maximum

0.77	-0.11	0.11	0.33	0.55	-0.11	0.33
-0.11	1.00	-0.11	0.33	-0.11	0.11	-0.11
0.11	-0.11	1.00	-0.33	0.11	-0.11	0.55
0.33	0.33	-0.33	0.55	-0.33	0.33	0.33
0.55	-0.11	0.11	-0.33	1.00	-0.11	0.11
-0.11	0.11	-0.11	0.33	-0.11	1.00	-0.11
0.33	-0.11	0.55	0.33	0.11	-0.11	0.77

1.00	0.33		

Pooling

maximum

0.77	-0.11	0.11	0.33	0.55	-0.11	0.33
-0.11	1.00	-0.11	0.33	-0.11	0.11	-0.11
0.11	-0.11	1.00	-0.33	0.11	-0.11	0.55
0.33	0.33	-0.33	0.55	-0.33	0.33	0.33
0.55	-0.11	0.11	-0.33	1.00	-0.11	0.11
-0.11	0.11	-0.11	0.33	-0.11	1.00	-0.11
0.33	-0.11	0.55	0.33	0.11	-0.11	0.77

1.00	0.33	0.55	

Pooling

maximum

0.77	-0.11	0.11	0.33	0.55	-0.11	0.33
-0.11	1.00	-0.11	0.33	-0.11	0.11	-0.11
0.11	-0.11	1.00	-0.33	0.11	-0.11	0.55
0.33	0.33	-0.33	0.55	-0.33	0.33	0.33
0.55	-0.11	0.11	-0.33	1.00	-0.11	0.11
-0.11	0.11	-0.11	0.33	-0.11	1.00	-0.11
0.33	-0.11	0.55	0.33	0.11	-0.11	0.77

1.00	0.33	0.55	0.33

Pooling

maximum

0.77	-0.11	0.11	0.33	0.55	-0.11	0.33
-0.11	1.00	-0.11	0.33	-0.11	0.11	-0.11
0.11	-0.11	1.00	-0.33	0.11	-0.11	0.55
0.33	0.33	-0.33	0.55	-0.33	0.33	0.33
0.55	-0.11	0.11	-0.33	1.00	-0.11	0.11
-0.11	0.11	-0.11	0.33	-0.11	1.00	-0.11
0.33	-0.11	0.55	0.33	0.11	-0.11	0.77

1.00	0.33	0.55	0.33
0.33			

Pooling

0.77	-0.11	0.11	0.33	0.55	-0.11	0.33
-0.11	1.00	-0.11	0.33	-0.11	0.11	-0.11
0.11	-0.11	1.00	-0.33	0.11	-0.11	0.55
0.33	0.33	-0.33	0.55	-0.33	0.33	0.33
0.55	-0.11	0.11	-0.33	1.00	-0.11	0.11
-0.11	0.11	-0.11	0.33	-0.11	1.00	-0.11
0.33	-0.11	0.55	0.33	0.11	-0.11	0.77

max pooling

1.00	0.33	0.55	0.33
0.33	1.00	0.33	0.55
0.55	0.33	1.00	0.11
0.33	0.55	0.11	0.77

0.77	-0.11	0.11	0.33	0.55	-0.11	0.33
-0.11	1.00	-0.11	0.33	-0.11	0.11	-0.11
0.11	-0.11	1.00	-0.33	0.11	-0.11	0.55
0.33	0.33	-0.33	0.55	-0.33	0.33	0.33
0.55	-0.11	0.11	-0.33	1.00	-0.11	0.11
-0.11	0.11	-0.11	0.33	-0.11	1.00	-0.11
0.33	-0.11	0.55	0.33	0.11	-0.11	0.77

0.33	-0.55	0.11	-0.11	0.11	-0.55	0.33
-0.55	0.55	-0.55	0.33	-0.55	0.55	-0.55
0.11	-0.55	0.55	-0.77	0.55	-0.55	0.11
-0.11	0.33	-0.77	1.00	-0.77	0.33	-0.11
0.11	-0.55	0.55	-0.77	0.55	-0.55	0.11
-0.55	0.55	-0.55	0.33	-0.55	0.55	-0.55
0.33	-0.55	0.11	-0.11	0.11	-0.55	0.33

0.33	-0.11	0.55	0.33	0.11	-0.11	0.77
-0.11	0.11	-0.11	0.33	-0.11	1.00	-0.11
0.55	-0.11	0.11	-0.33	1.00	-0.11	0.11
0.33	0.33	-0.33	0.55	-0.33	0.33	0.33
0.11	-0.11	1.00	-0.33	0.11	-0.11	0.55
-0.11	1.00	-0.11	0.33	-0.11	0.11	-0.11
0.77	-0.11	0.11	0.33	0.55	-0.11	0.33



1.00	0.33	0.55	0.33
0.33	1.00	0.33	0.55
0.55	0.33	1.00	0.11
0.33	0.55	0.11	0.77



0.55	0.33	0.55	0.33
0.33	1.00	0.55	0.11
0.55	0.55	0.55	0.11
0.33	0.11	0.11	0.33



0.33	0.55	1.00	0.77
0.55	0.55	1.00	0.33
1.00	1.00	0.11	0.55
0.77	0.33	0.55	0.33

Pooling layer

A stack of images becomes a stack of smaller images.

0.77	-0.11	0.11	0.33	0.55	-0.11	0.33
-0.11	1.00	-0.11	0.33	-0.11	0.11	-0.11
0.11	-0.11	1.00	-0.33	0.11	-0.11	0.55
0.33	0.33	-0.33	0.55	-0.33	0.33	0.33
0.55	-0.11	0.11	-0.33	1.00	-0.11	0.11
-0.11	0.11	-0.11	0.33	-0.11	1.00	-0.11
0.33	-0.11	0.55	0.33	0.11	-0.11	0.77

0.33	-0.55	0.11	-0.11	0.11	-0.55	0.33
-0.55	0.55	-0.55	0.33	-0.55	0.55	-0.55
0.11	-0.55	0.55	-0.77	0.55	-0.55	0.11
-0.11	0.33	-0.77	1.00	-0.77	0.33	-0.11
0.11	-0.55	0.55	-0.77	0.55	-0.55	0.11
-0.55	0.55	-0.55	0.33	-0.55	0.55	-0.55
0.33	-0.55	0.11	-0.11	0.11	-0.55	0.33

0.33	-0.11	0.55	0.33	0.11	-0.11	0.77
-0.11	0.11	-0.11	0.33	-0.11	1.00	-0.11
0.55	-0.11	0.11	-0.33	1.00	-0.11	0.11
0.33	0.33	-0.33	0.55	-0.33	0.33	0.33
0.11	-0.11	1.00	-0.33	0.11	-0.11	0.55
-0.11	1.00	-0.11	0.33	-0.11	0.11	-0.11
0.77	-0.11	0.11	0.33	0.55	-0.11	0.33

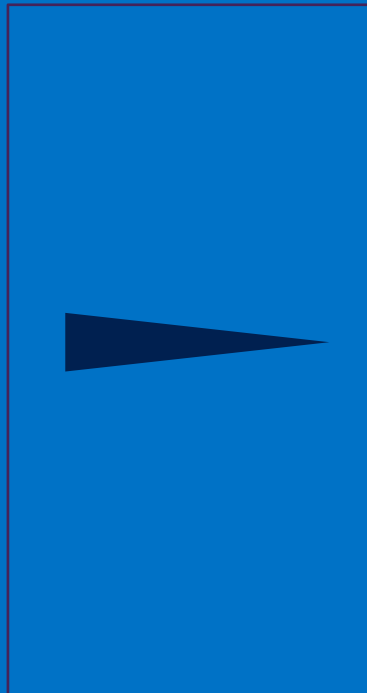

1.00	0.33	0.55	0.33
0.33	1.00	0.33	0.55
0.55	0.33	1.00	0.11
0.33	0.55	0.11	0.77

0.55	0.33	0.55	0.33
0.33	1.00	0.55	0.11
0.55	0.55	0.55	0.11
0.33	0.11	0.11	0.33

0.33	0.55	1.00	0.77
0.55	0.55	1.00	0.33
1.00	1.00	0.11	0.55
0.77	0.33	0.55	0.33

Normalization

Keep the math from breaking by tweaking each of the values just a bit.

Change everything negative to zero.

Rectified Linear Units (ReLUs)

0.77	-0.11	0.11	0.33	0.55	-0.11	0.33
-0.11	1.00	-0.11	0.33	-0.11	0.11	-0.11
0.11	-0.11	1.00	-0.33	0.11	-0.11	0.55
0.33	0.33	-0.33	0.55	-0.33	0.33	0.33
0.55	-0.11	0.11	-0.33	1.00	-0.11	0.11
-0.11	0.11	-0.11	0.33	-0.11	1.00	-0.11
0.33	-0.11	0.55	0.33	0.11	-0.11	0.77



0.77	0	0.11	0.33	0.55	0	0.33
0	1.00	0	0.33	0	0.11	0
0.11	0	1.00	0	0.11	0	0.55
0.33	0.33	0	0.55	0	0.33	0.33
0.55	0	0.11	0	1.00	0	0.11
0	0.11	0	0.33	0	1.00	0
0.33	0	0.55	0.33	0.11	0	0.77

ReLU layer

A stack of images becomes a stack of images with no negative values.

0.77	-0.11	0.11	0.33	0.55	-0.11	0.33
-0.11	1.00	-0.11	0.33	-0.11	0.11	-0.11
0.11	-0.11	1.00	-0.33	0.11	-0.11	0.55
0.33	0.33	-0.33	0.55	-0.33	0.33	0.33
0.55	-0.11	0.11	-0.33	1.00	-0.11	0.11
-0.11	0.11	-0.11	0.33	-0.11	1.00	-0.11
0.33	-0.11	0.55	0.33	0.11	-0.11	0.77

0.33	-0.55	0.11	-0.11	0.11	-0.55	0.33
-0.55	0.55	-0.55	0.33	-0.55	0.55	-0.55
0.11	-0.55	0.55	-0.77	0.55	-0.55	0.11
-0.11	0.33	-0.77	1.00	-0.77	0.33	-0.11
0.11	-0.55	0.55	-0.77	0.55	-0.55	0.11
-0.55	0.55	-0.55	0.33	-0.55	0.55	-0.55
0.33	-0.55	0.11	-0.11	0.11	-0.55	0.33

0.33	-0.11	0.55	0.33	0.11	-0.11	0.77
-0.11	0.11	-0.11	0.33	-0.11	1.00	-0.11
0.55	-0.11	0.11	-0.33	1.00	-0.11	0.11
0.33	0.33	-0.33	0.55	-0.33	0.33	0.33
0.11	-0.11	1.00	-0.33	0.11	-0.11	0.55
-0.11	1.00	-0.11	0.33	-0.11	0.11	-0.11
0.77	-0.11	0.11	0.33	0.55	-0.11	0.33

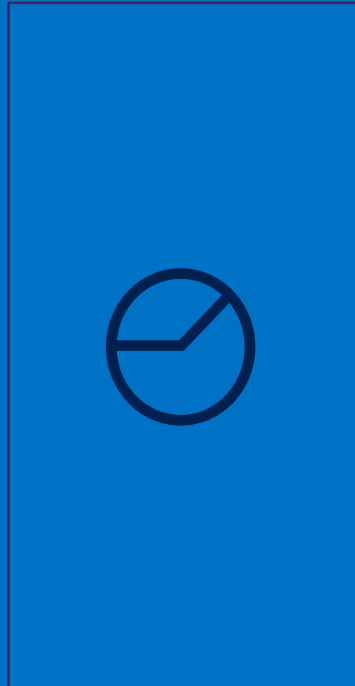

0.77	0	0.11	0.33	0.55	0	0.33
0	1.00	0	0.33	0	0.11	0
0.11	0	1.00	0	0.11	0	0.55
0.33	0.33	0	0.55	0	0.33	0.33
0.55	0	0.11	0	1.00	0	0.11
0	0.11	0	0.33	0	1.00	0
0.33	0	0.55	0.33	0.11	0	0.77

0.33	0	0.11	0	0.11	0	0.33
0	0.55	0	0.33	0	0.55	0
0.11	0	0.55	0	0.55	0	0.11
0	0.33	0	1.00	0	0.33	0
0.11	0	0.55	0	0.55	0	0.11
0	0.55	0	0.33	0	0.55	0
0.33	0	0.11	0	0.11	0	0.33

0.33	0	0.55	0.33	0.11	0	0.77
0	0.11	0	0.33	0	1.00	0
0.55	0	0.11	0	1.00	0	0.11
0.33	0.33	0	0.55	0	0.33	0.33
0.11	0	1.00	0	0.11	0	0.55
0	1.00	0	0.33	0	0.11	0
0.77	0	0.11	0.33	0.55	0	0.33

Layers get stacked

The output of one becomes the input of the next.

-1	-1	-1	-1	-1	-1	-1	-1	-1
-1	1	-1	-1	-1	-1	-1	1	-1
-1	-1	1	-1	-1	-1	1	-1	-1
-1	-1	-1	1	-1	1	-1	-1	-1
-1	-1	-1	-1	1	-1	-1	-1	-1
-1	-1	-1	1	-1	1	-1	-1	-1
-1	-1	1	-1	-1	-1	1	-1	-1
-1	1	-1	-1	-1	-1	-1	1	-1
-1	-1	-1	-1	-1	-1	-1	-1	-1



1.00	0.33	0.55	0.33
0.33	1.00	0.33	0.55
0.55	0.33	1.00	0.11
0.33	0.55	0.11	0.77

0.55	0.33	0.55	0.33
0.33	1.00	0.55	0.11
0.55	0.55	0.55	0.11
0.33	0.11	0.11	0.33

0.33	0.55	1.00	0.77
0.55	0.55	1.00	0.33
1.00	1.00	0.11	0.55
0.77	0.33	0.55	0.33

Deep stacking

Layers can be repeated several (or many) times.

-1	-1	-1	-1	-1	-1	-1	-1	-1
-1	1	-1	-1	-1	-1	-1	1	-1
-1	-1	1	-1	-1	-1	1	-1	-1
-1	-1	-1	1	-1	1	-1	-1	-1
-1	-1	-1	-1	1	-1	-1	-1	-1
-1	-1	1	-1	-1	1	-1	-1	-1
-1	1	-1	-1	-1	-1	-1	1	-1
-1	-1	-1	-1	-1	-1	-1	-1	-1

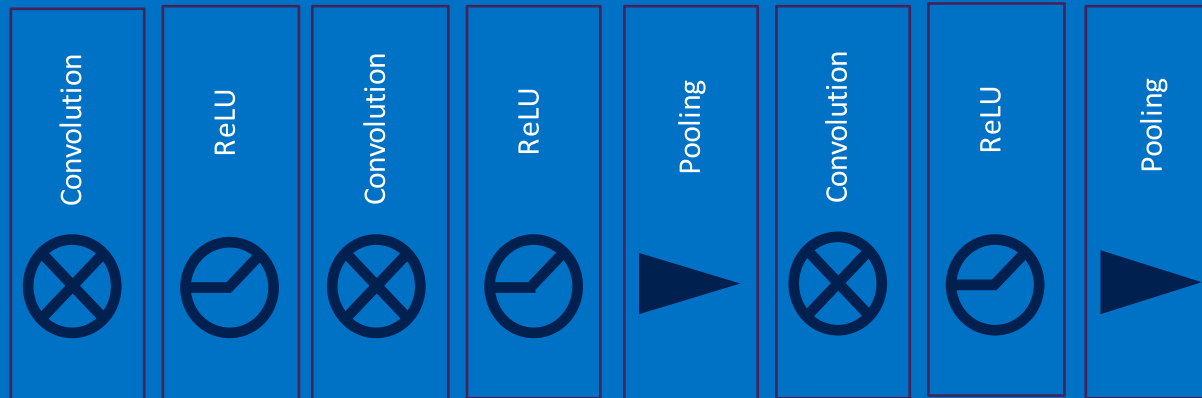

1.00	0.55
0.55	1.00
1.00	0.55
0.55	0.55
0.55	1.00
1.00	0.55

Fully connected layer

Every value gets a vote

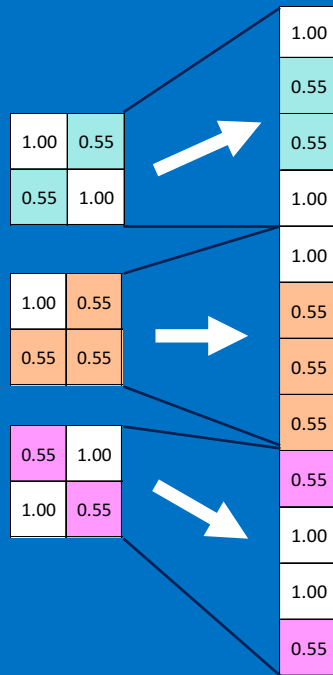

Fully connected layer

Vote depends on how strongly a value predicts X or O

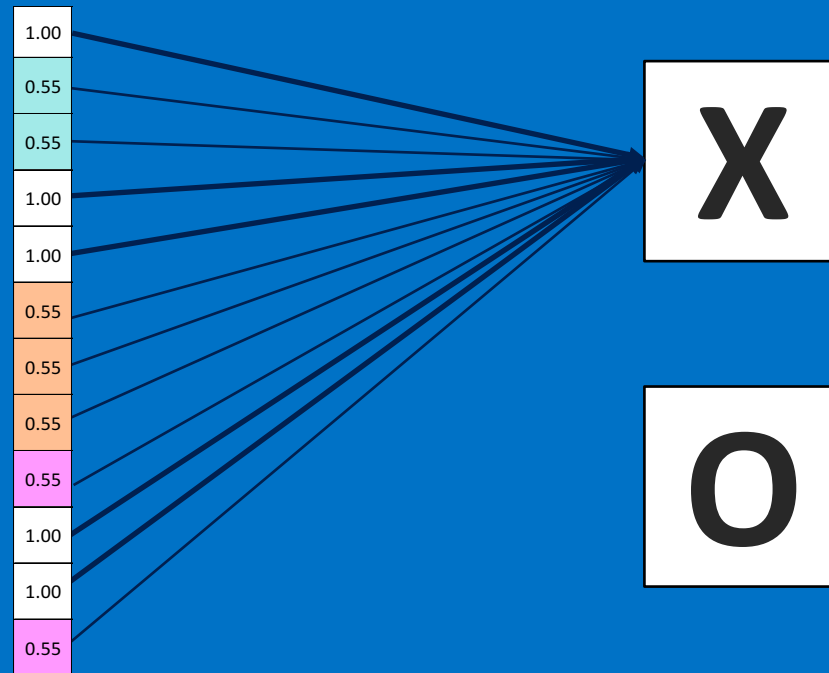

Fully connected layer

Vote depends on how strongly a value predicts X or O

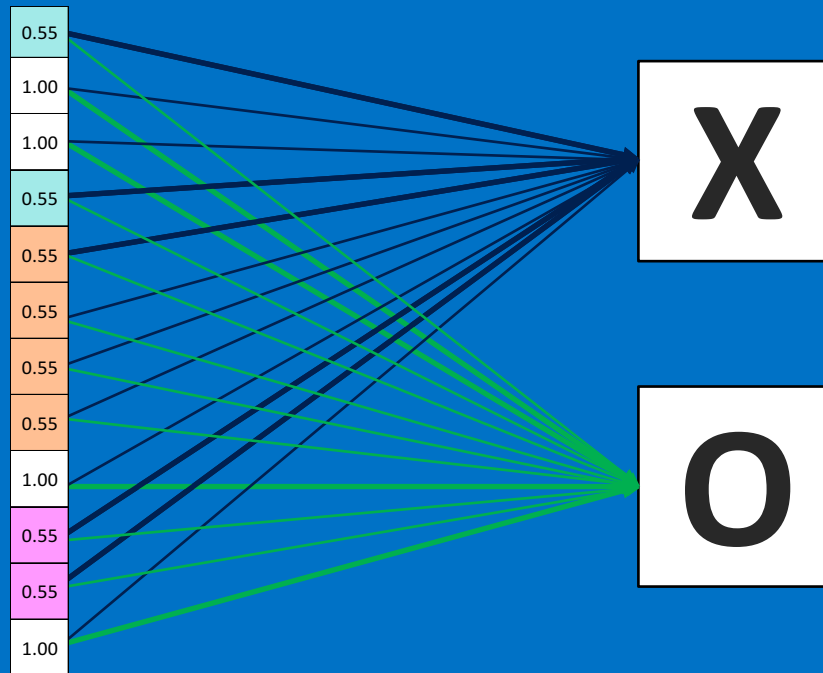

Fully connected layer

Future values vote on X or O

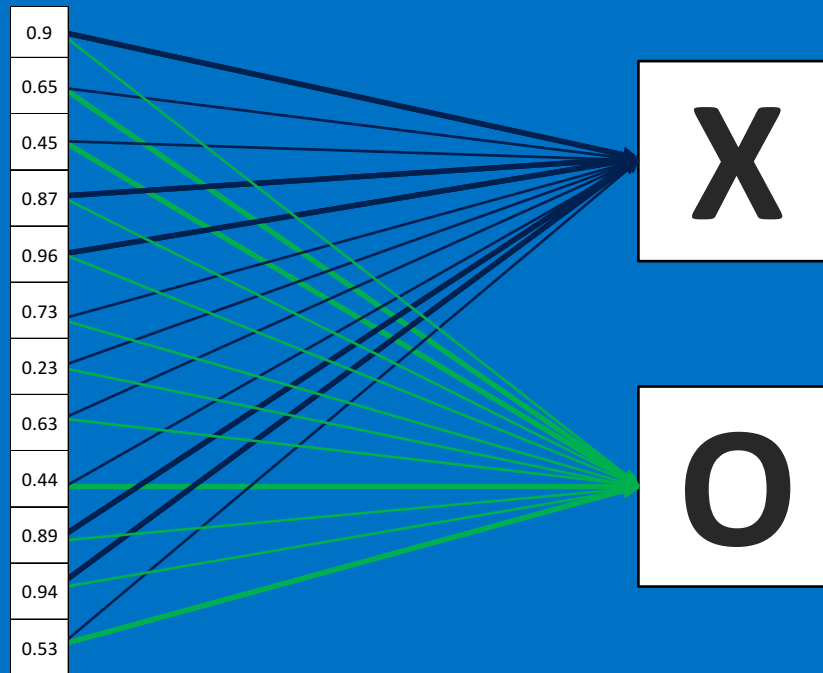

Fully connected layer

Future values vote on X or O

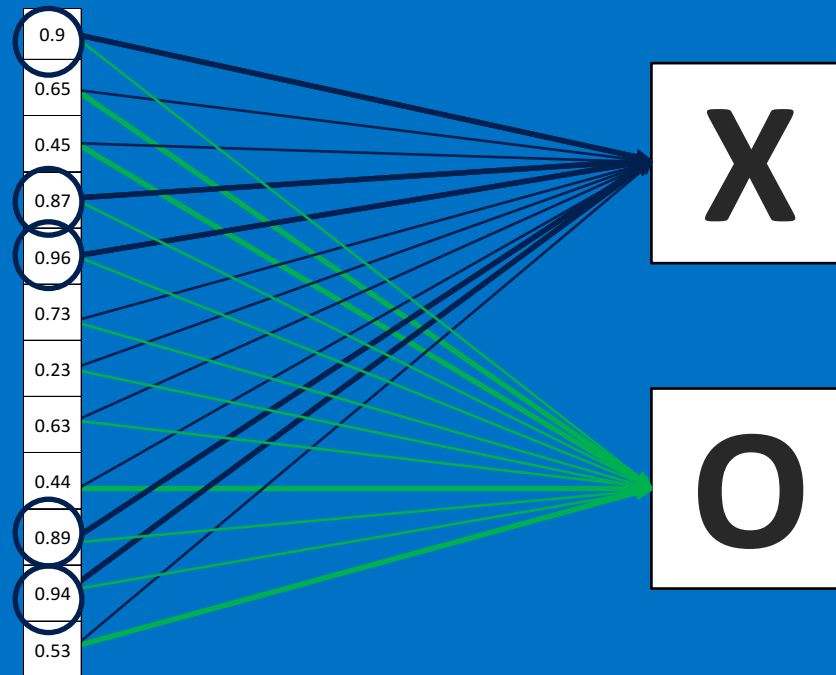

Fully connected layer

Future values vote on X or O

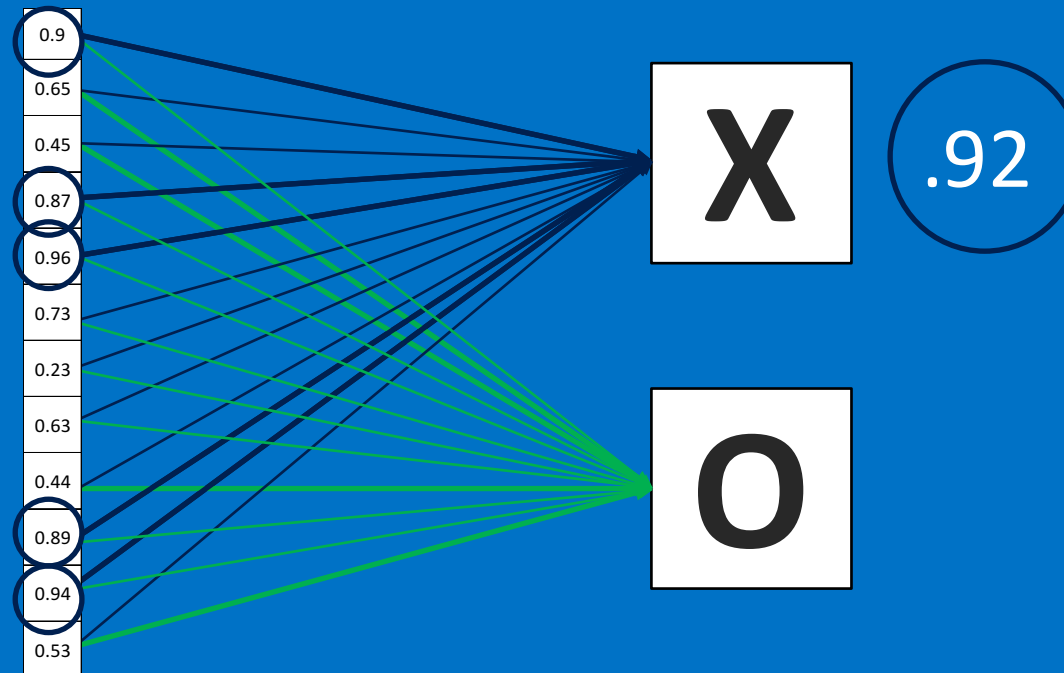

Fully connected layer

Future values vote on X or O

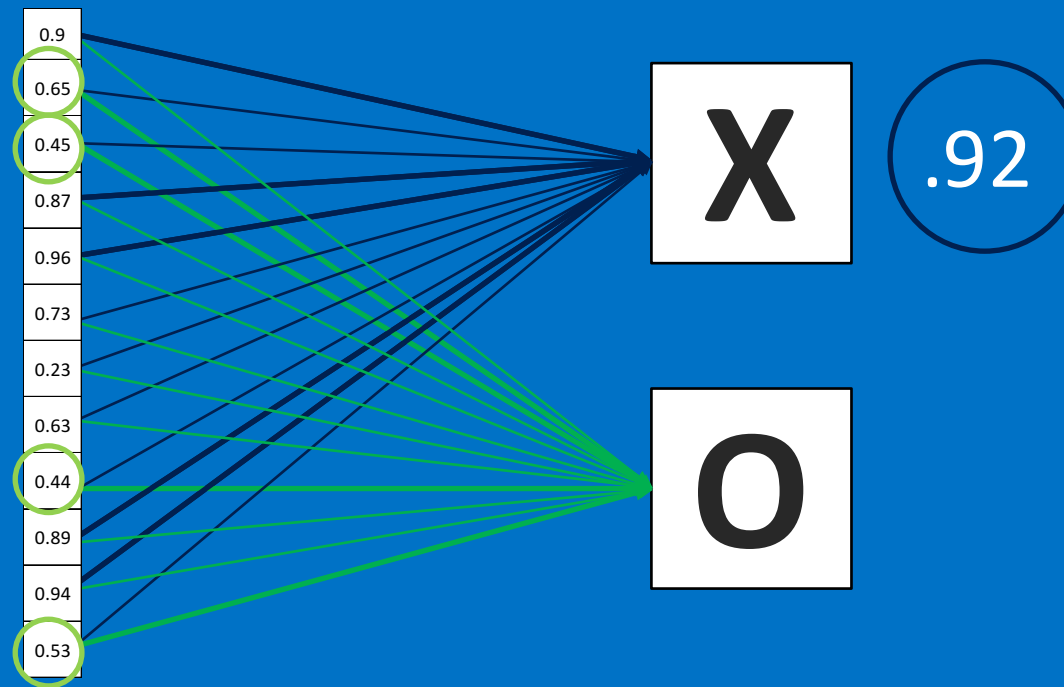

Fully connected layer

Future values vote on X or O

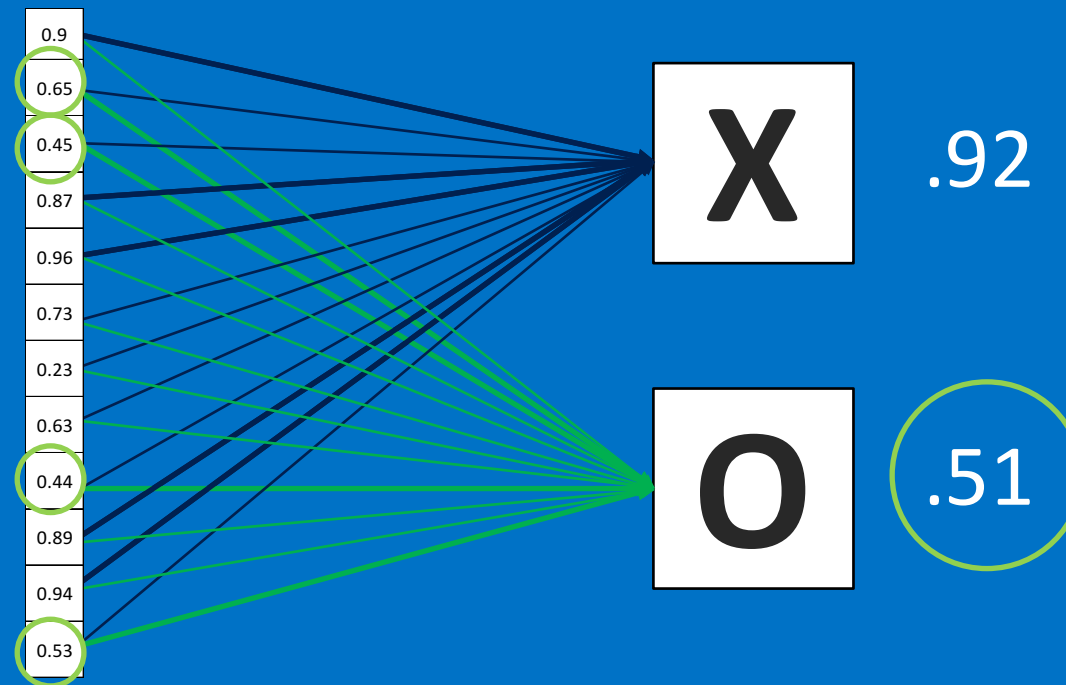

Fully connected layer

Future values vote on X or O

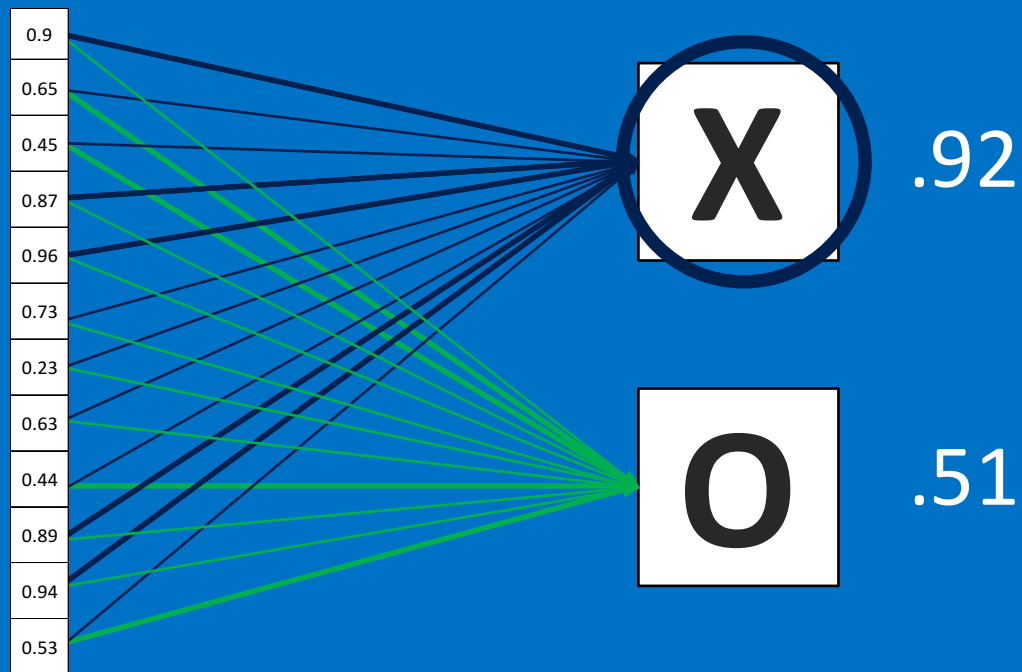

Fully connected layer

A list of feature values becomes a list of votes.

0.9
0.65
0.45
0.87
0.96
0.73
0.23
0.63
0.44
0.89
0.94
0.53

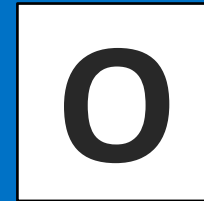
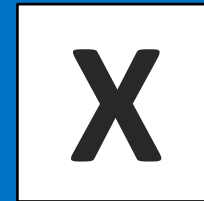
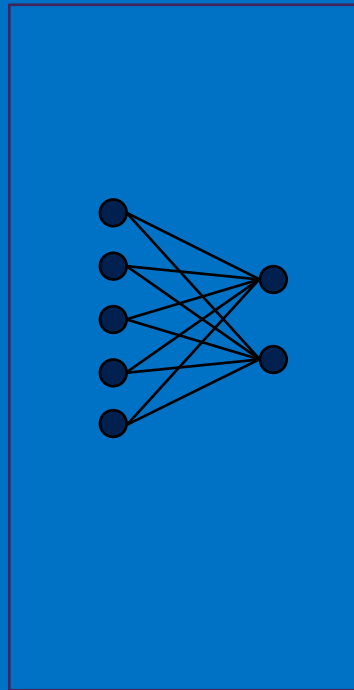

Fully connected layer

These can also be stacked.

0.9
0.65
0.45
0.87
0.96
0.73
0.23
0.63
0.44
0.89
0.94
0.53

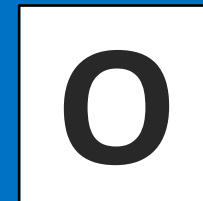
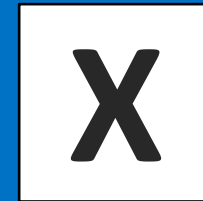
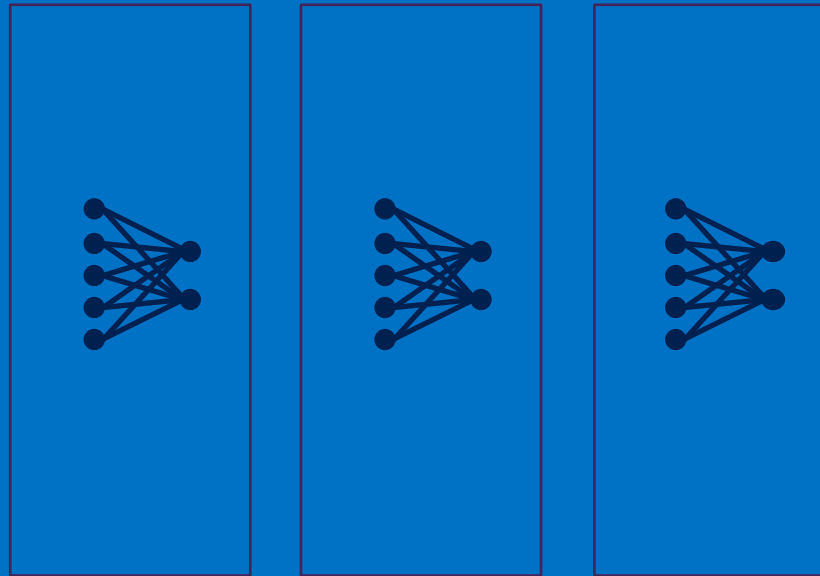

Putting it all together

A set of pixels becomes a set of votes.

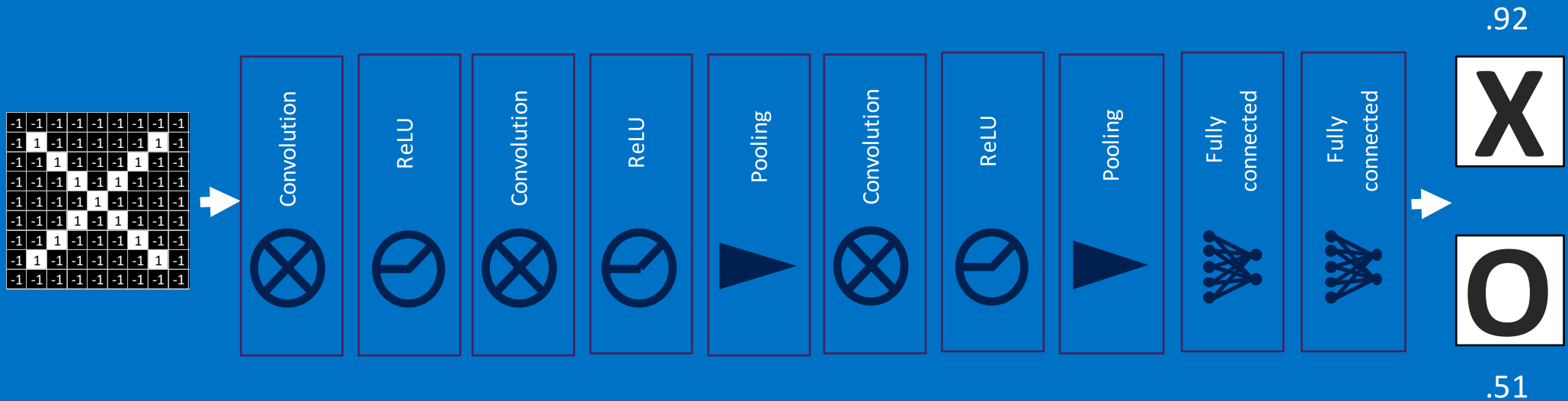

Learning

Q: Where do all the magic numbers come from?

Features in convolutional layers

Voting weights in fully connected layers

A: Backpropagation

Backprop

Error = right answer – actual answer

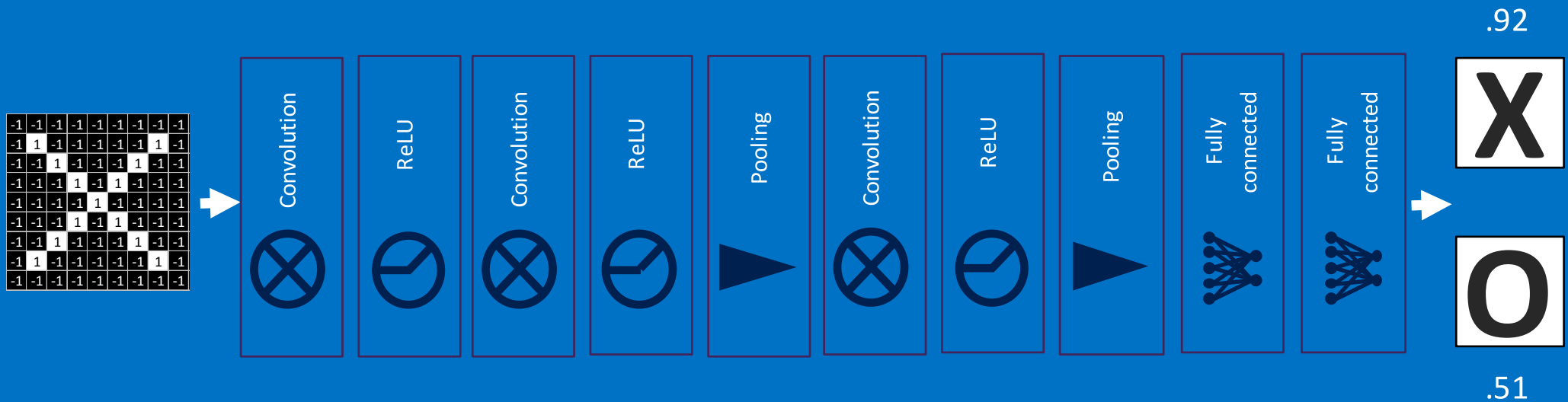

Backprop

	Right answer	Actual answer	Error
X	1		
O			

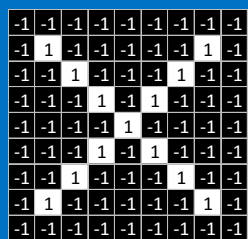

.51

Backprop

	Right answer	Actual answer	Error
X	1	0.92	
O			

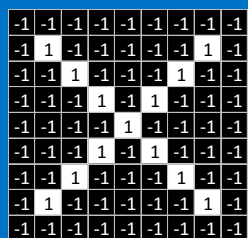

.51

Backprop

	Right answer	Actual answer	Error
X	1	0.92	0.08
O			

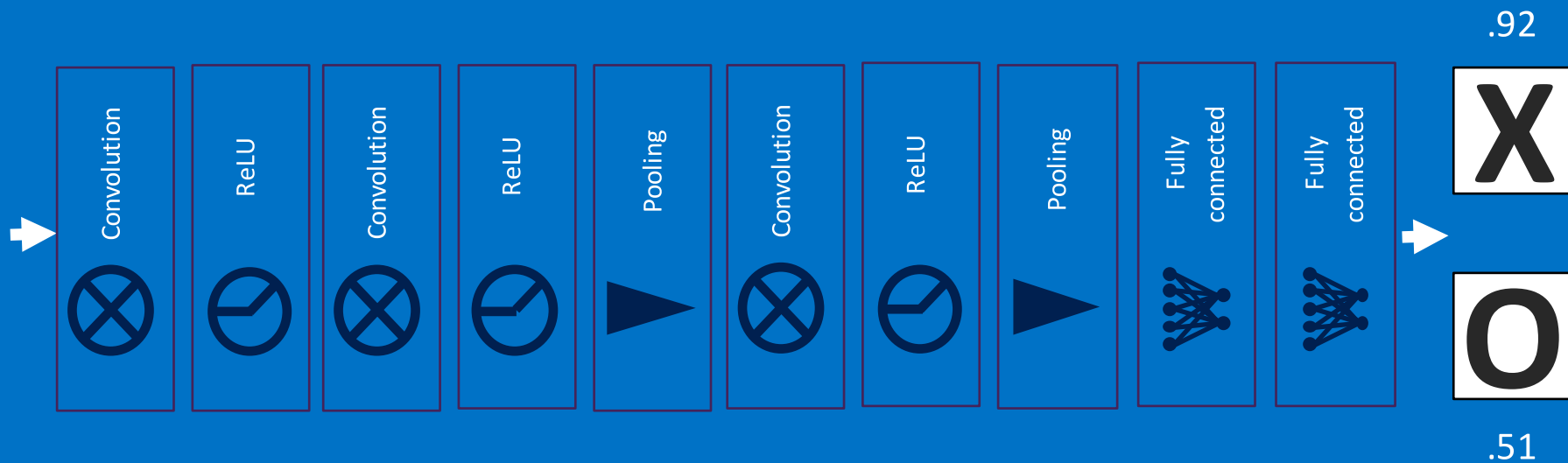
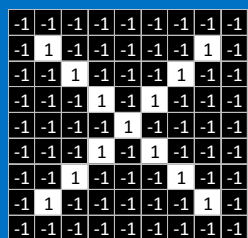

Backprop

	Right answer	Actual answer	Error
X	1	0.92	0.08
O	0	0.51	0.49

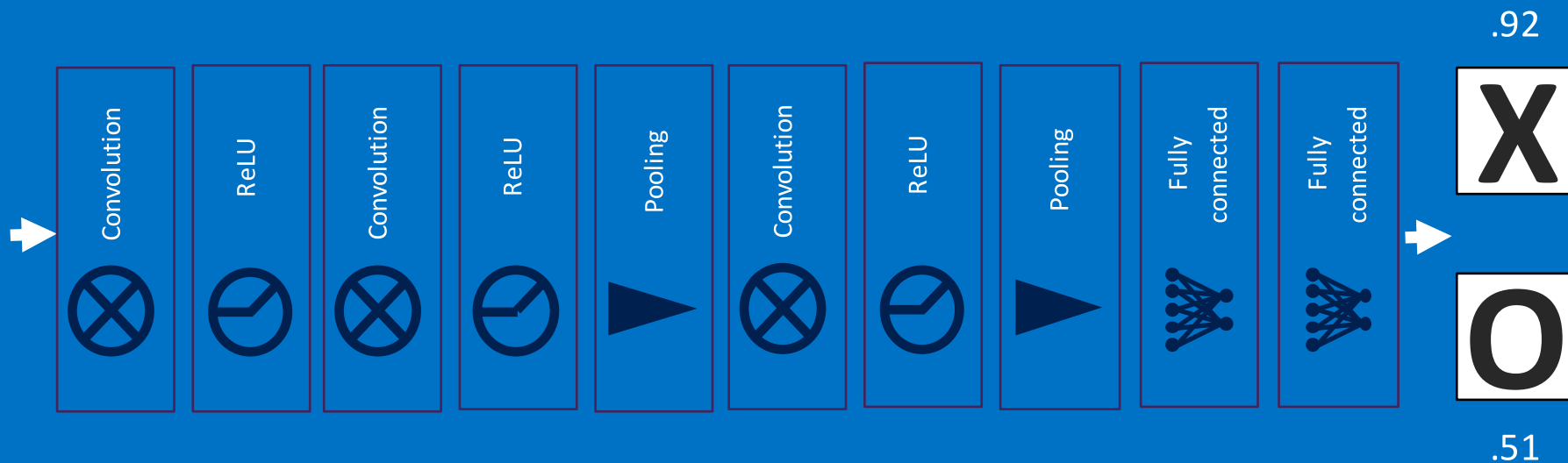
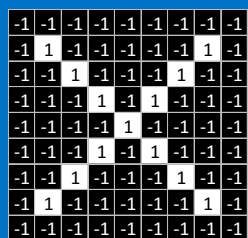

Backprop

	Right answer	Actual answer	Error
X	1	0.92	0.08
O	0	0.51	0.49
		Total	0.57

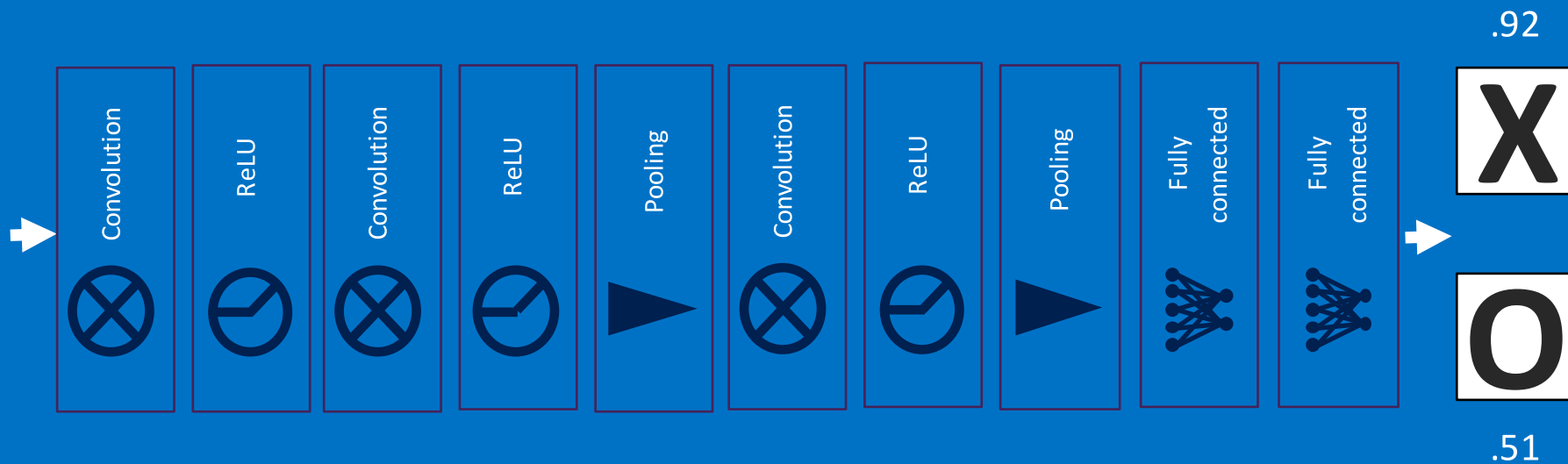
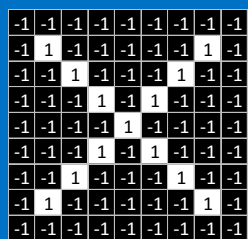

Gradient descent

For each feature pixel and voting weight, adjust it up and down a bit and see how the error changes.

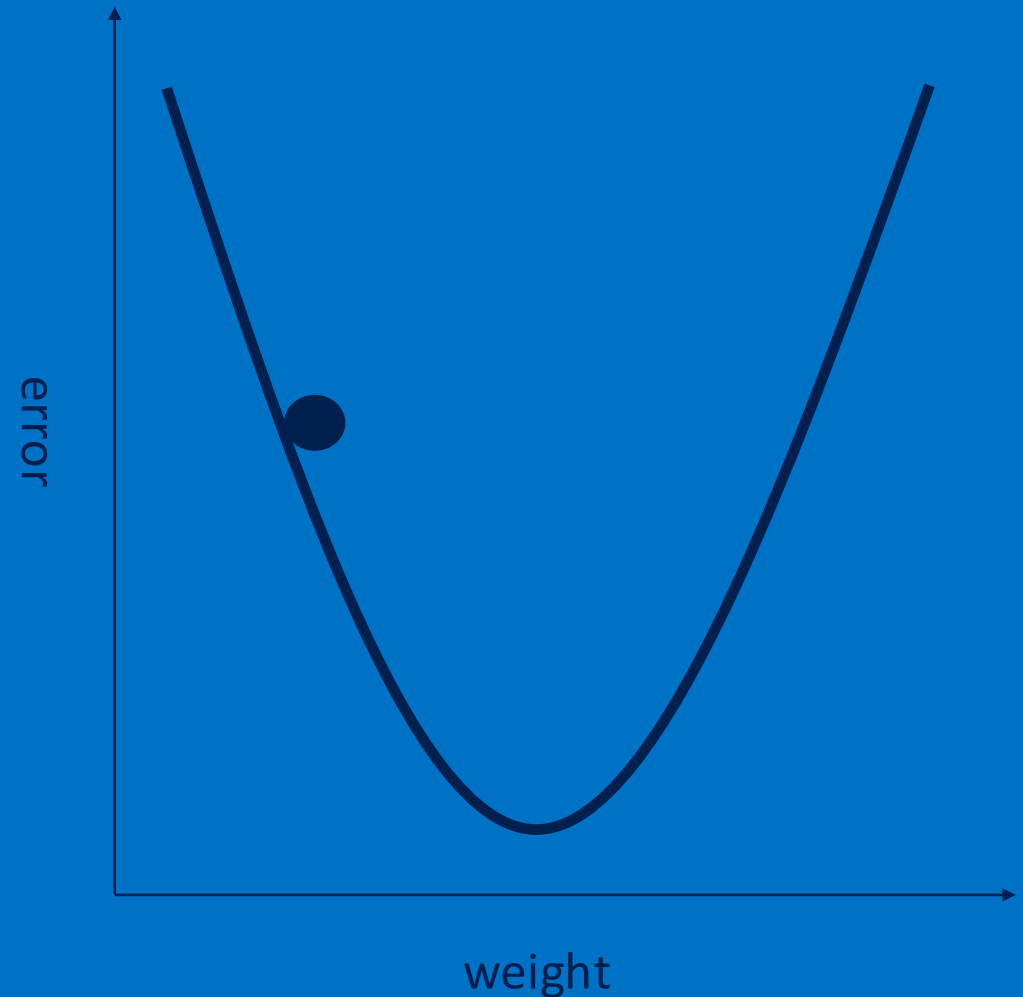

Gradient descent

For each feature pixel and voting weight, adjust it up and down a bit and see how the error changes.

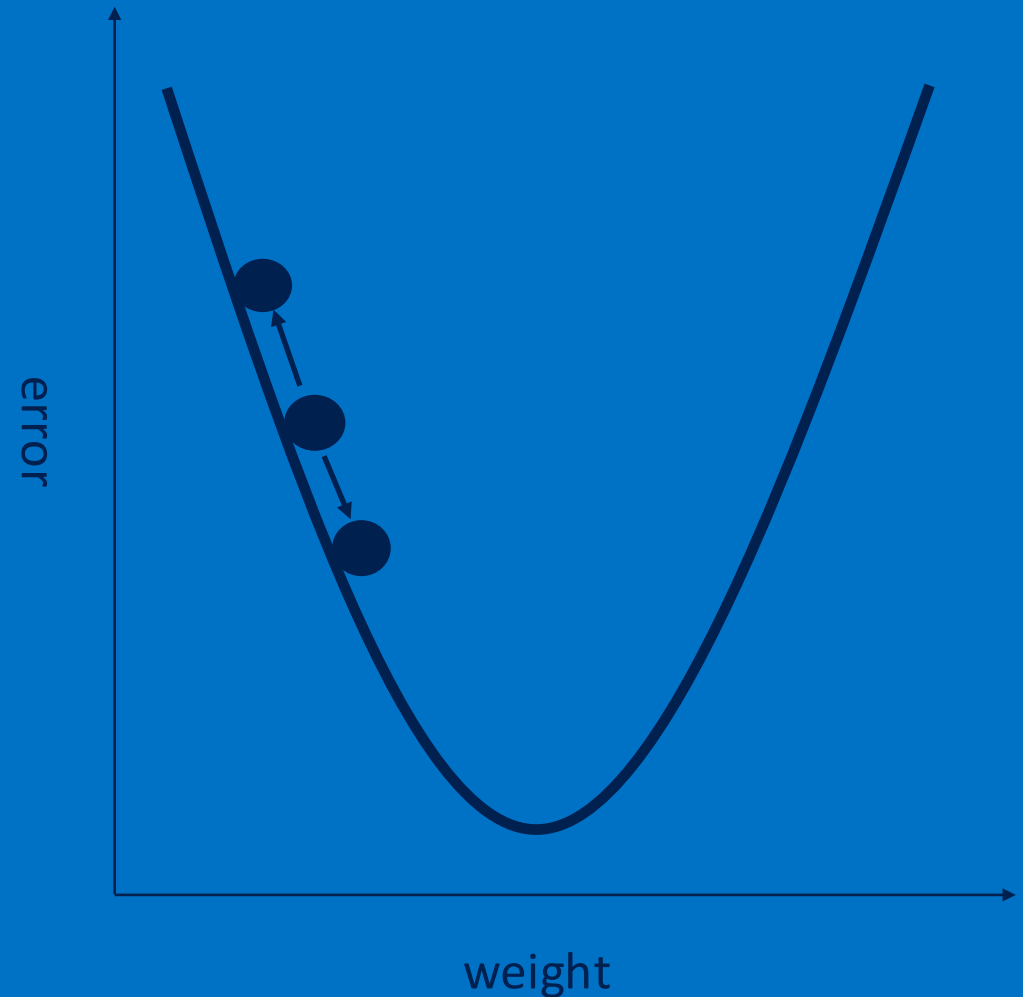

Hyperparameters (knobs)

Convolution

- Number of features

- Size of features

Pooling

- Window size

- Window stride

Fully Connected

- Number of neurons

Architecture

How many of each type of layer?

In what order?

Not just images

Any 2D (or 3D) data.

Things closer together are more closely related than things far away.

Sound

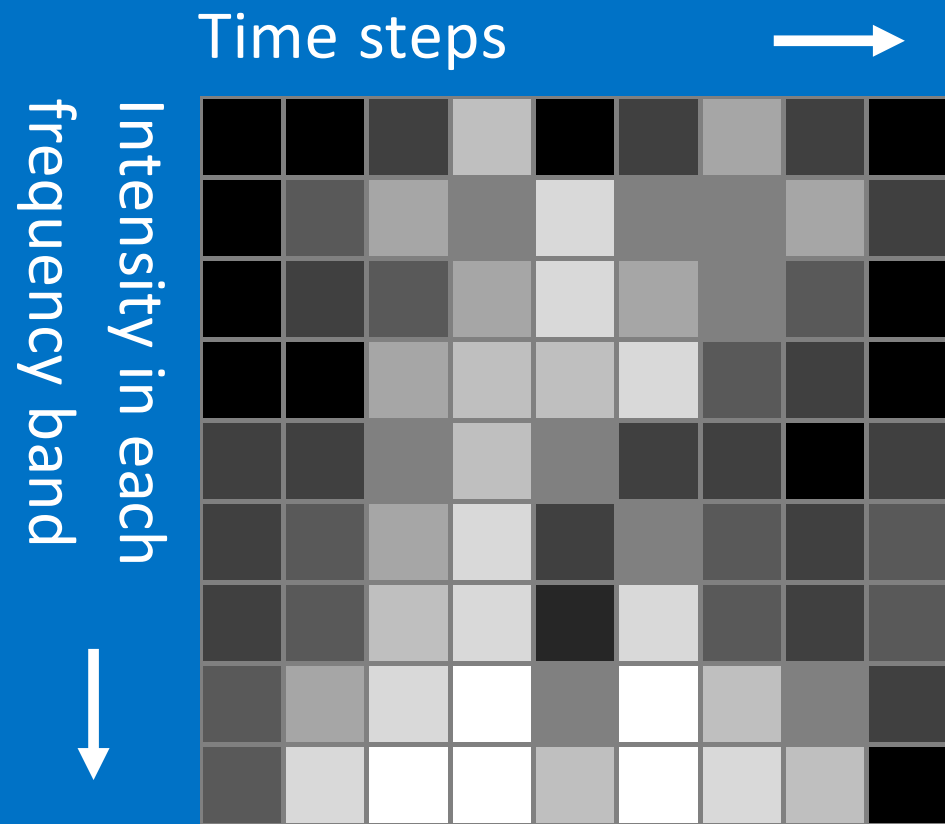

Text

Position in
sentence



Words in
dictionary

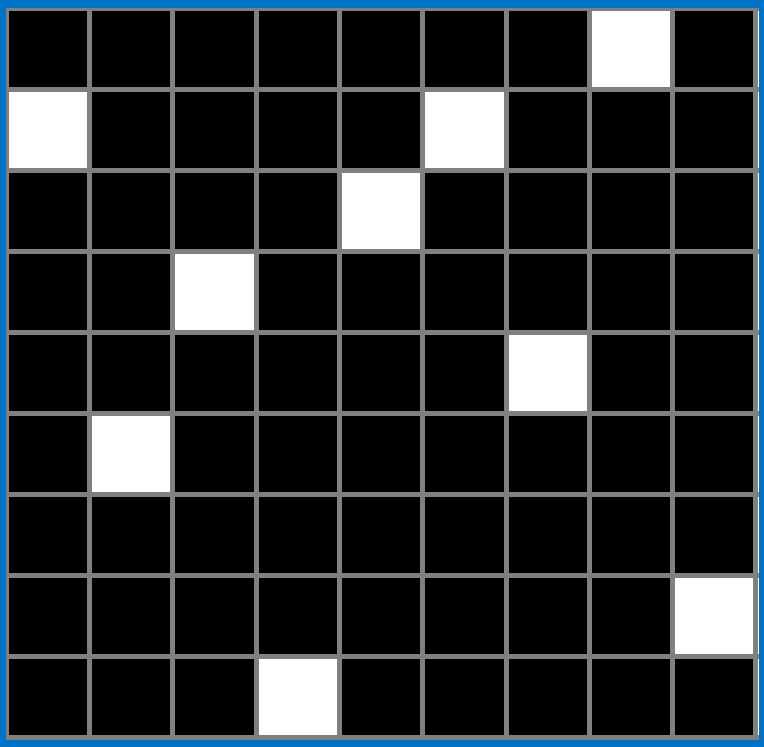

Limitations

ConvNets only capture local “spatial” patterns in data.
If the data can't be made to look like an image, ConvNets are less useful.

Compare this to SIFT

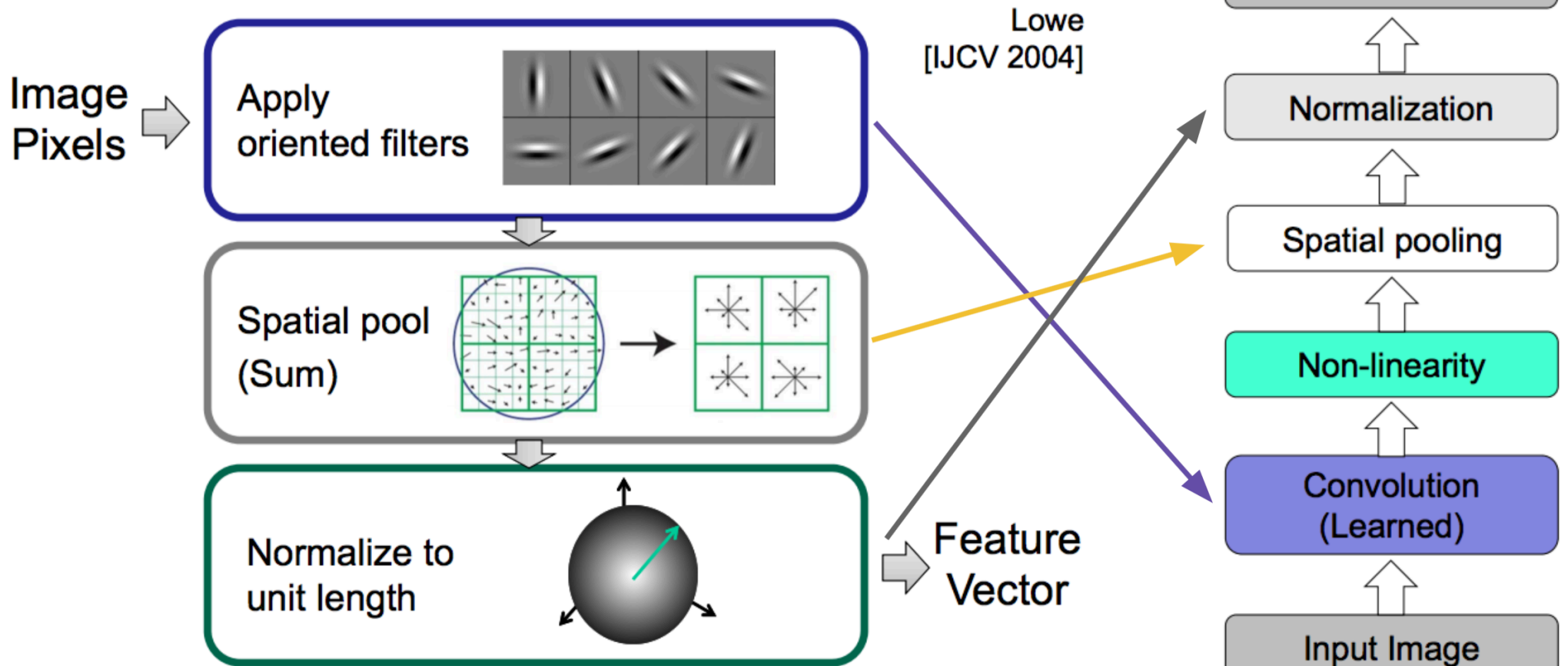

Case Study: ResNet

[He et al., 2015]

Solution: Use network layers to fit a residual mapping instead of directly trying to fit a desired underlying mapping

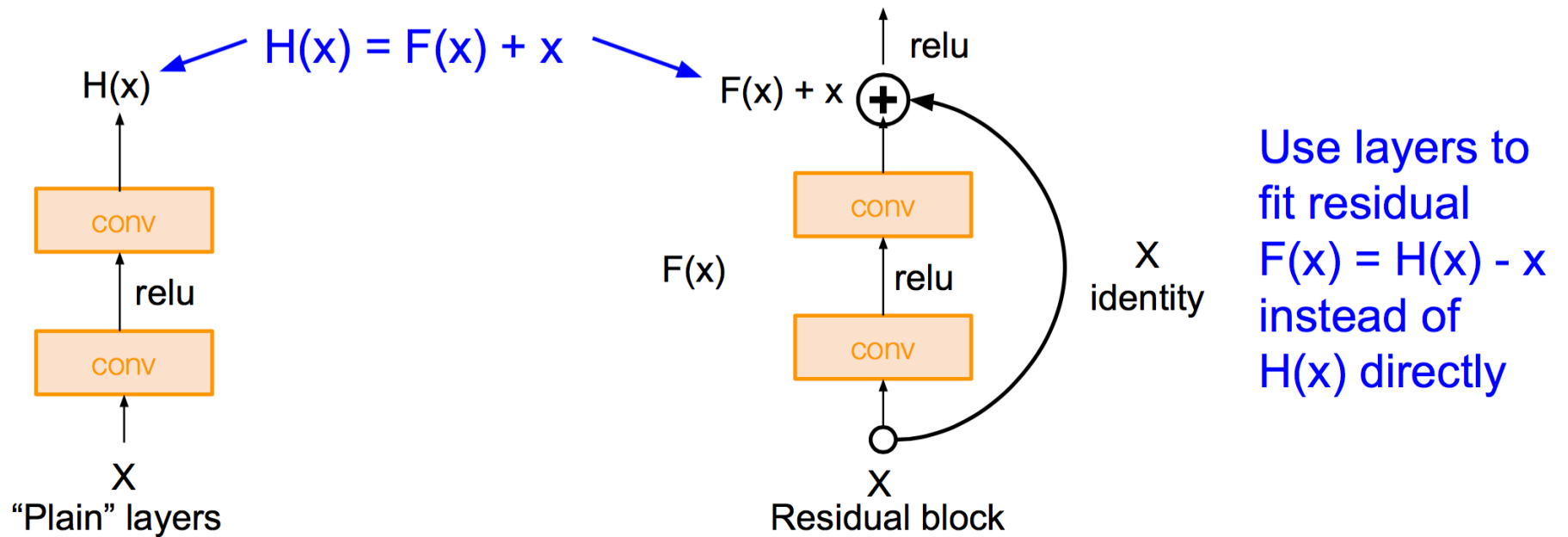

Case Study: ResNet

[He et al., 2015]

Full ResNet architecture:

- Stack residual blocks
- Every residual block has two 3x3 conv layers
- Periodically, double # of filters and downsample spatially using stride 2 (/2 in each dimension)
- Additional conv layer at the beginning
- No FC layers at the end (only FC 1000 to output classes)

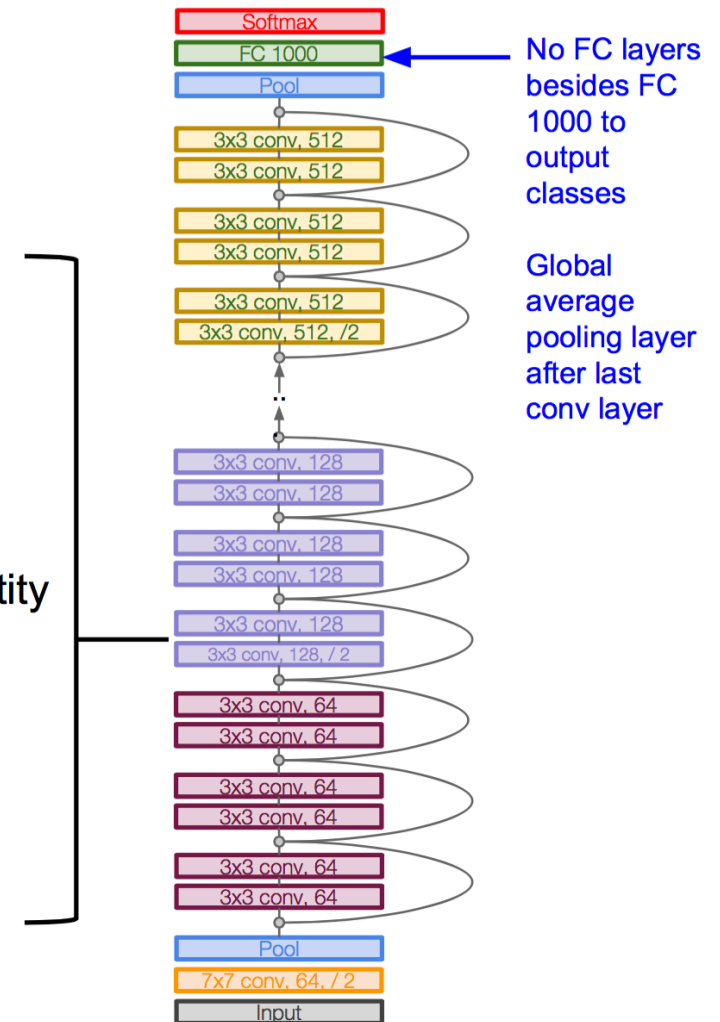
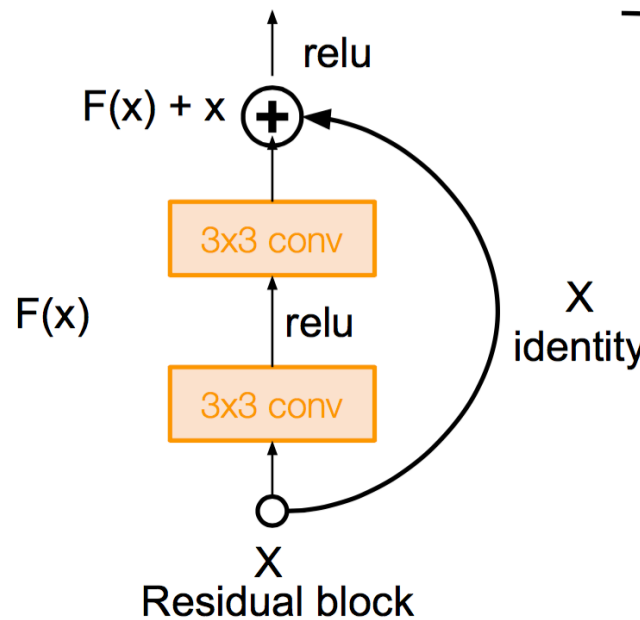

Slide: Stanford CS231n

R-CNN: Regions with CNN features

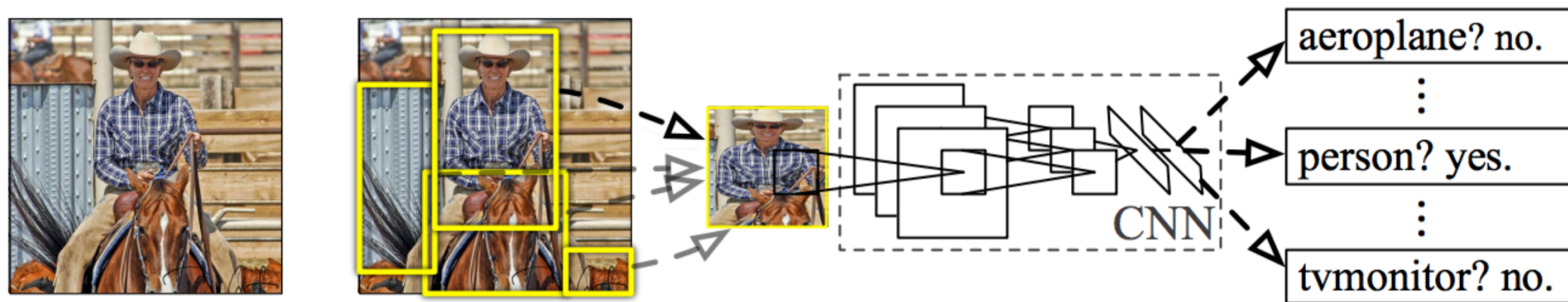

Input
image

Extract region
proposals (~2k / image)

Compute CNN
features

Classify
regions

Best performing method on PASCAL 2012

Detection improving previous methods by 30%

Slide: [R. Girshick](#)

Thanks!